

Regulation

VM iSense Pro – AD283



Installation and Service Manual

Contents

1	Safety instructions	4
	1.1 General safety instructions	4
	1.2 Recommendations	5
	1.3 Liabilities	6
	1.3.1 Manufacturer's liability	6
	1.3.2 Installer's liability	6
2	About this manual	7
	2.1 Symbols used	7
	2.2 Abbreviations	7
3	Technical specifications	8
	3.1 Certifications	8
	3.2 Operating modes	8
	3.2.1 Appliance set to OTH+3WV	8
	3.2.2 Appliance set to 0/1+V3V	8
	3.3 Description of the keys	9
	3.4 Description of the display	10
	3.4.1 Key functions	10
	3.4.2 Flame symbol	10
	3.4.3 Solar (If connected)	10
	3.4.4 Operating modes	11
	3.4.5 Domestic Hot Water override	11
	3.4.6 Other information	12
	3.5 SOLARFIRST System	12
	3.6 Technical specifications	12
4	Installation	13
	4.1 Package list	13
	4.2 Mounting	13
	4.3 Electrical connections	14
	4.3.1 Recommendations	14
	4.3.2 Access to the connection terminal	14
	4.3.3 Description of the connection terminal block	15
	4.3.4 Connection to the terminal block	16
	4.3.5 Connecting the BUS cable	16

- 4.4 Installation and connection examples - Appliance set to OTH+3WV17**
 - 4.4.1 Independent control system17
 - 4.4.2 Cascade of boilers equipped with OTH bus25
- 4.5 Installation and connection examples - Appliance set to 0/1+V3V28**
 - 4.5.1 Independent control system28
 - 4.5.2 Slave control system in cascade34
- 4.6 Electrical connection diagram36**
- 5 Operating the appliance38**
 - 5.1 Powering up for the first time38**
 - 5.2 Access to the various browsing levels39**
 - 5.2.1 User level39
 - 5.2.2 Installer level39
 - 5.2.3 After Sales level40
 - 5.3 Browsing in the menus40**
 - 5.4 Reading out measured values41**
 - 5.5 Settings after powering up for the first time42**
 - 5.5.1 Displaying the parameters in extended mode42
 - 5.5.2 Setting the parameters specific to the installation43
 - 5.5.3 Naming the circuits and generators45
 - 5.5.4 Setting the heating curve46
 - 5.6 Changing the settings48**
 - 5.6.1 Language selection48
 - 5.6.2 Defining the configuration mode49
 - 5.6.3 Calibrating the sensors49
 - 5.6.4 Professional settings50
 - 5.6.5 Configuring the network57
 - 5.6.6 Return to the factory settings60

6	Switching off the appliance	61
	6.1 Installation shutdown	61
	6.2 Antifreeze protection	61
7	Troubleshooting	62
	7.1 Installer's contact details	62
	7.2 Messages (type code Mxx)	62
	7.3 Message history	63
	7.4 Faults	64
	7.4.1 Deletion of sensors from the memory in the PCB	66
	7.5 Failure history	67
	7.6 Parameter and input/output check (mode tests)	67
8	Spare parts	70
	8.1 General	70
	8.2 Spare parts	71

1 Safety instructions

1.1 General safety instructions



WARNING

This appliance can be used by children aged from 8 years and above and persons with reduced physical, sensory or mental capabilities or lack of experience and knowledge if they have been given supervision or instruction concerning use of the appliance in a safe way and understand the hazards involved. Children shall not play with the appliance. Cleaning and user maintenance shall not be made by children without supervision.



CAUTION

Before any work, switch off the mains supply to the appliance.



CAUTION

Any operation on the installation must be performed by a qualified technician respecting professional regulations and in accordance with this document.



CAUTION

Solar installations must be earthed to protect them against lightning.



CAUTION

Operation of the thermostatic mixing valve on the solar hot water tank outlet must be checked on commissioning of the solar system.



CAUTION

Use only original spare parts.

**CAUTION**

Before any work, switch off the mains supply to the appliance. Protect the installation against any unwanted restarts.

1.2 Recommendations

**CAUTION**

Do not neglect to service the appliance. Service the appliance regularly to ensure that it operates correctly.

**WARNING**

Only qualified professionals are authorised to work on the appliance and the installation.

**WARNING**

Heating water and domestic water must not come into contact with each other. Domestic water must not circulate via the exchanger.

- ▶ To take advantage of the guarantee, no modifications must be made to the appliance.
- ▶ To reduce heat losses as much as possible, insulate the pipes.

Casing components

Only remove the casing for maintenance and repair operations. Put the casing back in place after maintenance and repair operations.

Instructions stickers

The instructions and warnings affixed to the appliance must never be removed or covered and must remain legible during the entire lifespan of the appliance. Immediately replace damaged or illegible instructions and warning stickers.

1.3 Liabilities

1.3.1. Manufacturer's liability

Our products are manufactured in compliance with the requirements of the various applicable European Directives. They are therefore delivered with **CE** marking and all relevant documentation.

In the interest of customers, we are continuously endeavouring to make improvements in product quality. All the specifications stated in this document are therefore subject to change without notice.

Our liability as the manufacturer may not be invoked in the following cases:

- ▶ Failure to abide by the instructions on using the appliance.
- ▶ Faulty or insufficient maintenance of the appliance.
- ▶ Failure to abide by the instructions on installing the appliance.

1.3.2. Installer's liability

The installer is responsible for the installation and commissioning of the appliance. The installer must respect the following instructions:

- ▶ Read and follow the instructions given in the manuals provided with the appliance.
- ▶ Carry out installation in compliance with the prevailing legislation and standards.
- ▶ Perform the initial start up and carry out any checks necessary.
- ▶ Explain the installation to the user.
- ▶ If a maintenance is necessary, warn the user of the obligation to check the appliance and maintain it in good working order.
- ▶ Give all the instruction manuals to the user.

2 About this manual

2.1 Symbols used

In these instructions, various danger levels are employed to draw the user's attention to particular information. In so doing, we wish to safeguard the user's safety, highlight hazards and guarantee correct operation of the appliance.

**DANGER**

Risk of a dangerous situation causing serious physical injury.

**WARNING**

Risk of a dangerous situation causing slight physical injury.

**CAUTION**

Risk of material damage.



Signals important information.



Signals a referral to other instructions or other pages in the instructions.

2.2 Abbreviations

- ▶ **DHW**: Domestic hot water
- ▶ **3WV**: 3-way valve

3 Technical specifications

3.1 Certifications

This product complies to the requirements to the european directives and following standards:

- ▶ 2006/95/EC Low Voltage Directive. Reference Standard: EN60.335.1.
- ▶ 2004/108/EC Electromagnetic Compatibility Directive. Generic standards: EN1000-6-3 , EN 61000-6-1.

3.2 Operating modes

3.2.1. Appliance set to OTH+3WW

Independent control system

- ▶ ON/OFF and temperature control of the boiler.
- ▶ Circuits B, C, DHW and AUX available.
- ▶ Requires an outside temperature sensor.

Cascade of boilers equipped with OTH bus

- ▶ ON/OFF and temperature control of the boiler.
- ▶ Circuits B, C, DHW and AUX available.
- ▶ Requires an outside temperature sensor.
- ▶ 1 to 10VM iSense Pro modules configured as **OTH+3WW** or generators equipped with a DIEMATIC-m3 / iSense Pro control panel or an OTH MODBUS interface + 20VM iSense Pro modules configured as **VM/MR**.
- ▶ DHW priority is activated on all of the system’s secondary circuits.

3.2.2. Appliance set to 0/1+V3V

Independent control system

- ▶ Control of the boiler with an ON/OFF inlet.
- ▶ Circuits B, C and DHW available.
- ▶ **S.AUX** used for the ON/OFF command.
- ▶ The **AUX** outlet provides 230V.
- ▶ Requires an outside temperature sensor.

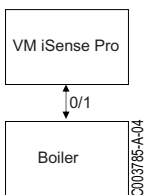
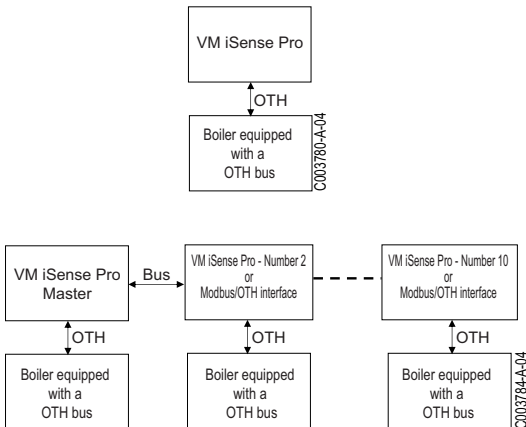

Slave control system in cascade

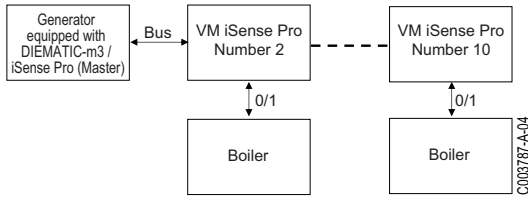

- ▶ Circuits B, C and DHW available.
- ▶ **S.AUX** used for the ON/OFF command.
- ▶ Does not require an outside temperature sensor.
- ▶ The VM iSense Pro module is always a slave in a cascade installation.
- ▶ DHW priority is activated on all of the system’s secondary circuits.

3.3 Description of the keys

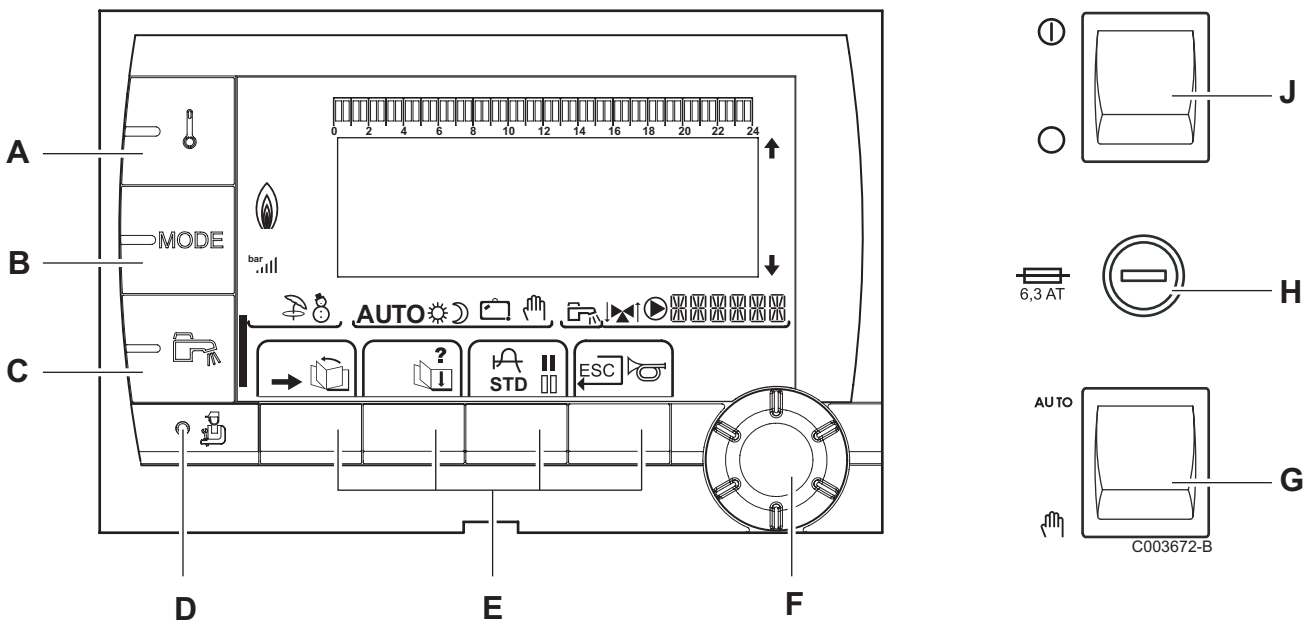

- A** Temperature setting key (heating, DHW, swimming pool)
- B** Operating mode selection key
- C** DHW override key
- D** Key to access the parameters reserved for the installer
- E** Keys on which the function varies as and when selections are made
- F** Rotary setting button:
 - ▶ Turn the rotary button to scroll through the menus or modify a value
 - ▶ Press the rotary button to access the selected menu or confirm a value modification
- G** Button AUTO/MANU
- H** Fuse
- J** Button ON/OFF

3.4 Description of the display

3.4.1. Key functions

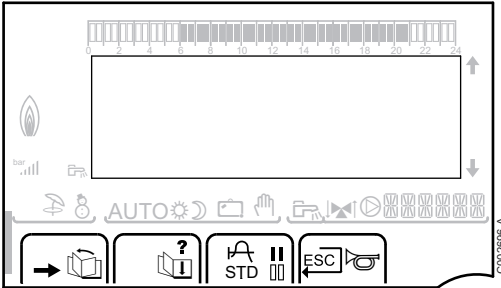

- Access to the various menus
- Used to scroll through the menus
- Used to scroll through the parameters
- ? The symbol is displayed when help is available
- Used to display the curve of the parameter selected
- STD** Reset of the time programmes
- Selection of comfort mode or selection of the days to be programmed
- Selection of reduced mode or deselection of the days to be programmed
- Back to the previous level
- ESC** Back to the previous level without saving the modifications made

3.4.2. Flame symbol

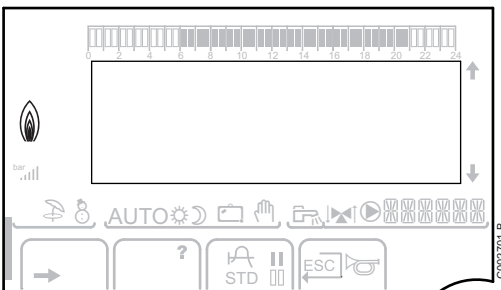

- ▶ The symbol is displayed: The burner is operating.
- ▶ The symbol is not displayed: The burner is off.

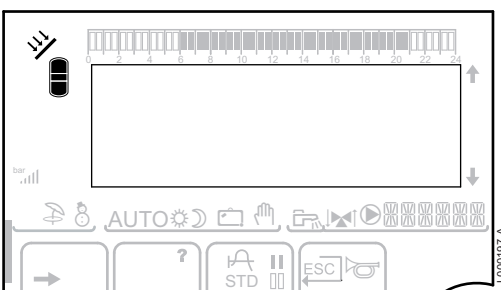

3.4.3. Solar (If connected)





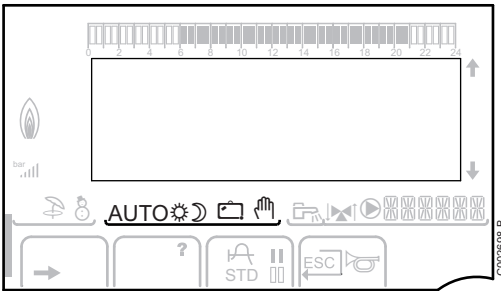
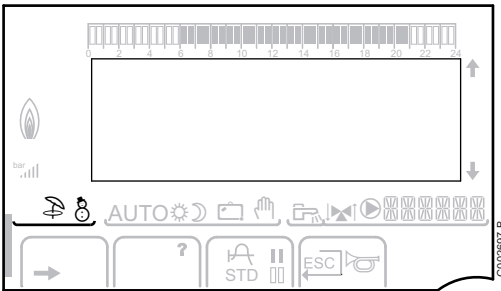

- The solar load pump is running
- The top part of the tank is reheated to the tank set point
- The entire tank is reheated to the tank set point
- The entire tank is reheated to the solar tank set point
- The tank is not loaded - Presence of the solar control system

3.4.4. Operating modes



-  Summer mode: The heating is off. Domestic hot water continues to be produced
-  WINTER mode: Heating and domestic hot water working

- AUTO** Operation in automatic mode according to the timer programme
-  Comfort mode: The symbol is displayed when a DAY override (comfort) is activated
 - ▶ Flashing symbol: Temporary override
 - ▶ Steady symbol: Permanent override
-  Reduced mode: The symbol is displayed when a NIGHT override (reduced) is activated
 - ▶ Flashing symbol: Temporary override
 - ▶ Steady symbol: Permanent override
-  Holiday mode: The symbol is displayed when a HOLIDAY override (antifreeze) is activated
 - ▶ Flashing symbol: Holiday mode programmed
 - ▶ Steady symbol: Holiday mode active
-  Manual mode: The boiler operates with the displayed set point. All of the pumps operate. The 3-way valves are not controlled.

3.4.5. Domestic Hot Water override

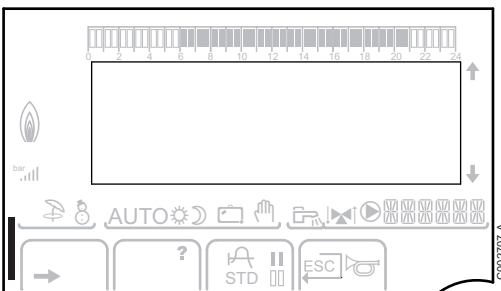

- A bar is displayed when a DHW override is activated:
- ▶ Flashing bar: Temporary override
 - ▶ Steady bar: Permanent override

3.4.6. Other information

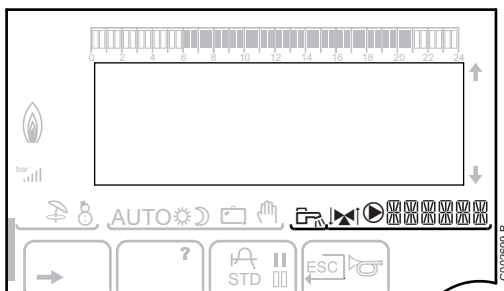

- The symbol is displayed when domestic hot water production is running.
- Valve indicator: The symbol is displayed when a 3-way valve is connected.
 - ▶ : 3-way valve opens
 - ▶ : 3-way valve closes
- The symbol is displayed when the pump is operating.
- Name of the circuit for which the parameters are displayed.

3.5 SOLARFIRST System

The RemaSol Ai control system signals the activation of the solar pump to the iSensePRO boiler control system. The iSensePRO boiler control system then lowers the temperature set for heating the domestic water to 1 - 30 K (value adjustable). This therefore results in priority being given to solar heat. If the solar pump is stopped because the solar energy is insufficient, the boiler returns to "normal" operating mode. The solar regulator and the boiler regulator operate in tandem on Remeha:

- ▶ To increase the recovered solar energy
- ▶ To reduce gas consumption.

3.6 Technical specifications

- ▶ Electricity supply: 230 V - 50 Hz
- ▶ Output: 10 - 1450 W

Outside sensor												
Temperature in °C	-20	-16	-12	-8	-4	0	4	8	12	16	20	24
Resistance in Ω	2392	2088	1811	1562	1342	1149	984	842	720	616	528	454

Outlet sensor circuit B+C Domestic hot water sensor System sensor											
Temperature in °C	0	10	20	25	30	40	50	60	70	80	90
Resistance in Ω	32014	19691	12474	10000	8080	5372	3661	2535	1794	1290	941

4 Installation

4.1 Package list

The delivery includes:

- ▶ The VM iSense Pro module
- ▶ Quick installation guide
- ▶ USB stick with the installation and service manual and the user guide

4.2 Mounting

The **VM iSense Pro** module can be affixed to the wall or in an electrical cabinet.

1. Drill 3 holes.
(1) Drilling template
2. Affix the module.
3. Open the protective hood.
4. Secure the unit with the 3 screws.

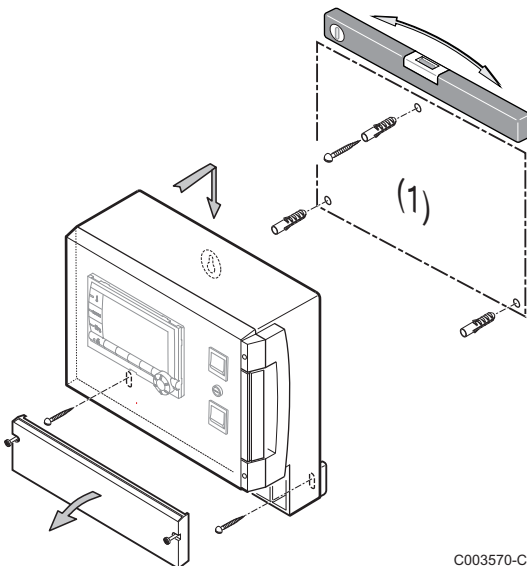

C003570-C



CAUTION

- ▶ Do not fit a power relay or a power circuit at a distance of less than 10 cm from the box.
- ▶ Failure to comply with these instructions could lead to interference and control unit malfunctioning or even damage to the electronic circuitry.

4.3 Electrical connections

4.3.1. Recommendations



WARNING

- ▶ Only qualified professionals may carry out electrical connections, always with the power off.
- ▶ The appliance is fully pre-wired. Do not modify the connections inside the control panel.
- ▶ Earth the appliance before making any electrical connections.

Make the electrical connections of the appliance according to:

- ▶ The instructions of the prevailing standards.
- ▶ The instructions on the electrical diagrams provided with the boiler.
- ▶ The manufacturer's instructions.



CAUTION

- ▶ Separate the sensor cables from the 230 V cables.
- ▶ Use 2 pipes or cable guides at least 10 cm apart.
- ▶ Keep to the polarity shown on the terminals: phase (L), neutral (N) and earth \perp .



CAUTION

Failure to comply with these instructions could lead to interference and control unit malfunctioning or even damage to the electronic circuitry.

4.3.2. Access to the connection terminal

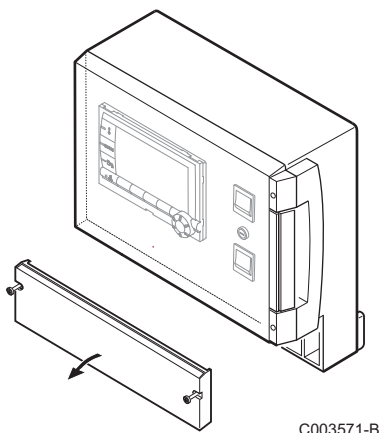

1. Unscrew the 2 screws.
2. Open the protective hood.

4.3.3. Description of the connection terminal block

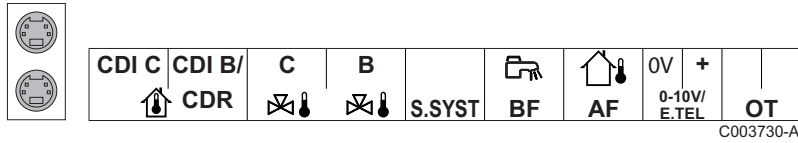

	Connecting the BUS cascade BUS cable - Package AD124 / AD134 / DB119	S.SYST	System sensor - Package AD250
CDI C	Remote control (Circuit C) - Package AD258	BF	DHW sensor - Package AD212
CDI B / CDR	Remote control (Circuit B) - Package AD258 Radio remote control - Circuit B/C - Package AD256	AF	Outside sensor - Package FM46 Outside radio-controlled temperature sensor - Package AD251
C	Outlet sensor circuit C - Package AD199	0-10 V / E.TEL	Inlet 0-10 Volts voice remote monitoring module - Package AD152
B	Outlet sensor circuit B - Package AD199	OT	OpenTherm

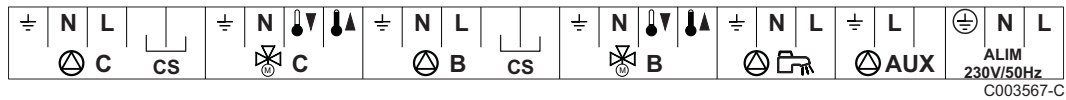

C	Heating pump circuit C	B	3 way valve circuit B
CS	Safety contact - Factory fitted bridge ⁽¹⁾		D.H.W. load pump
C	3 way valve circuit C	AUX	Auxiliary pump
B	Heating pump circuit B	ALIM 230 V/50Hz	Electricity supply
CS	Safety contact - Factory fitted bridge ⁽¹⁾		

(1) If using underfloor heating, remove the bridge CS and connect a safety thermostat.

4.3.4. Connection to the terminal block

To connect a wire to the terminal block, proceed as follows:

1. Strip 8 mm of wire.
Maximum cross section of the wire: 1.5 mm²
2. Press the spring in the terminal block with a screwdriver.
3. Insert the wire into the terminal block.

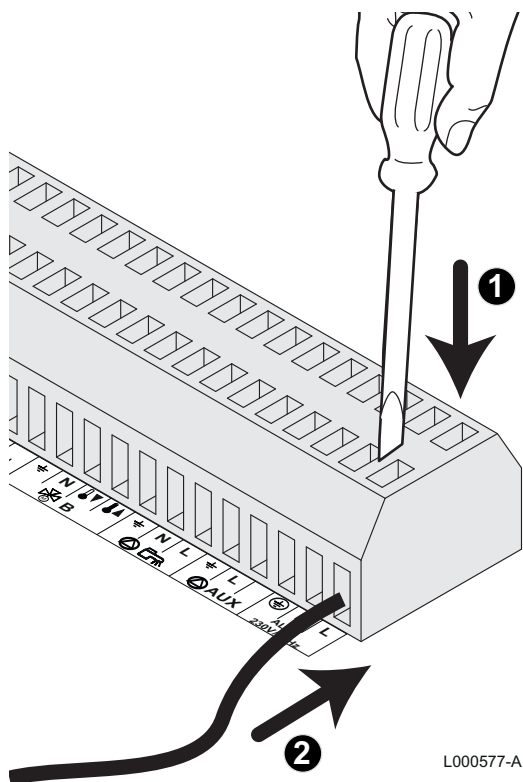

4.3.5. Connecting the BUS cable

To connect a shielded 2 wire cable, use an existing AD124 bus cable with mini-DIN connector and proceed as follows:

1. Cut the BUS cable.
2. Connect the 4 wires of the BUS cable to the 3 contact terminal block.

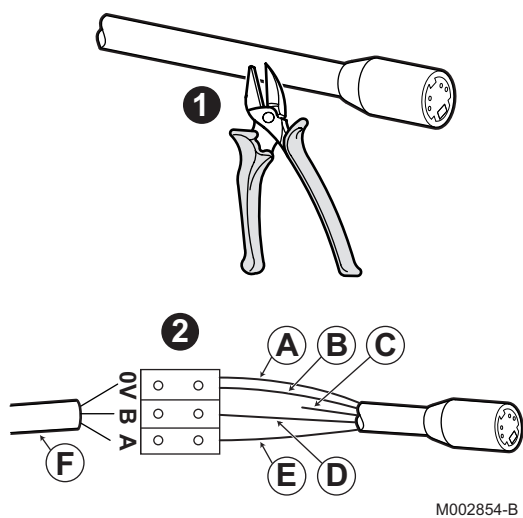

- A** Braided shield (Terminal 0V)
- B** Brown wire (Terminal 0V)
- C** Green wire (DO NOT USE)
- D** White wire (Terminal B)
- E** Yellow wire (Terminal A)
- F** 2 wire shielded cable

4.4 Installation and connection examples - Appliance set to OTH+3WV

4.4.1. Independent control system

■ 1 mixed heating circuit

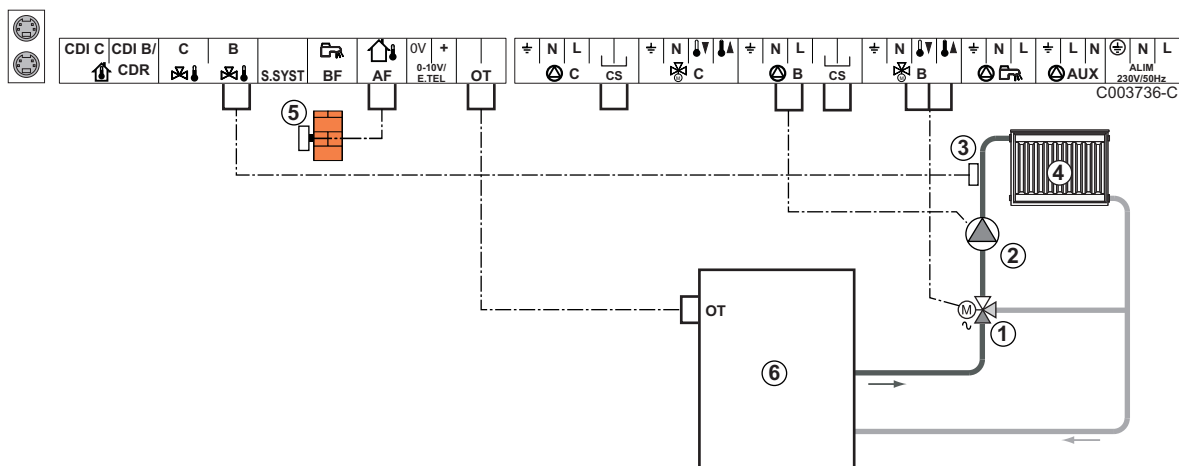

- ① 3 way valve circuit B
- ② Heating pump circuit B
- ③ Outlet sensor circuit B
- ④ Heating circuit B
- ⑤ Outside sensor (optional)
- ⑥ Boiler with OpenTherm inlet



- ▶ Earth the various pumps and 3-way valves.
- ▶ Connect a safety thermostat if the heating circuit is for underfloor heating.

Settings to be made for this type of installation			
Parameters	Access	Settings to be made	See chapter
CIRC.CURVE B	Installer level #SECONDARY INSTAL.P Menu	To be customised	"Setting the heating curve", page 46
MAX. CIRC. B	Installer level #SECONDARY LIMITS Menu	To be customised	"Professional settings", page 50

■ 2 mixed heating circuits and 1 DHW circuit

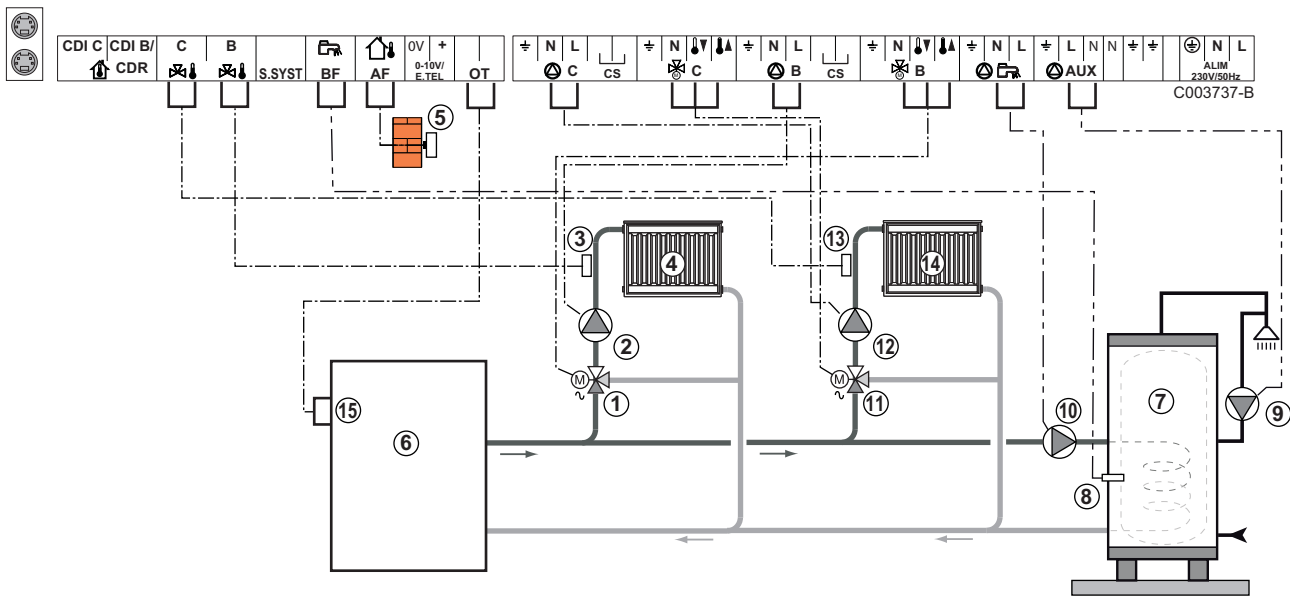

- ① 3 way valve circuit B
- ② Heating pump circuit B
- ③ Outlet sensor circuit B
- ④ Heating circuit B
- ⑤ Outside sensor
- ⑥ Primary
- ⑦ DHW storage tank
- ⑧ DHW sensor
- ⑨ Domestic circulation loop pump (Optional)
- ⑩ D.H.W. load pump
- ⑪ 3 way valve circuit C
- ⑫ Heating pump circuit C
- ⑬ Outlet sensor circuit C
- ⑭ Heating circuit C
- ⑮ Boiler's OT terminal block

i Connect a safety thermostat if the heating circuit is for underfloor heating.

Settings to be made for this type of installation			
Parameters	Access	Settings to be made	See chapter
CIRC.CURVE B	Installer level #SECONDARY INSTAL.P Menu	To be customised	"Setting the heating curve", page 46
MAX. CIRC. B	Installer level #SECONDARY LIMITS Menu	To be customised	"Professional settings", page 50

■ 1 direct heating circuit + 1 mixed heating circuit + 1 DHW circuit

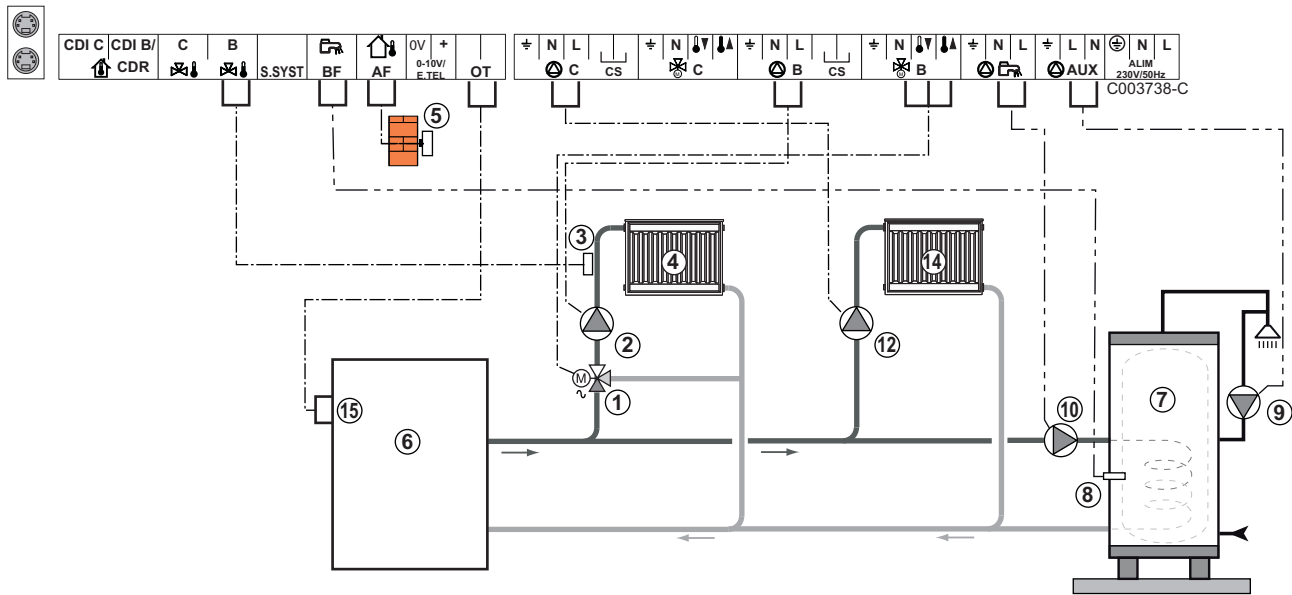

- ① 3 way valve circuit B
- ② Heating pump circuit B
- ③ Outlet sensor circuit B
- ④ Heating circuit B
- ⑤ Outside sensor
- ⑥ Primary
- ⑦ DHW storage tank
- ⑧ DHW sensor
- ⑨ Domestic circulation loop pump (Optional)
- ⑩ D.H.W. load pump
- ⑫ Heating pump circuit C
- ⑭ Heating circuit C
- ⑮ Boiler's OT terminal block



- ▶ Earth the various pumps and 3-way valves.
- ▶ Connect a safety thermostat if the heating circuit is for underfloor heating.

Settings to be made for this type of installation			
Parameters	Access	Settings to be made	See chapter
INSTALLATION	Installer level #SYSTEM Menu	EXTENDED	"Displaying the parameters in extended mode", page 42
CIRC.CURVE B	Installer level #SECONDARY INSTAL.P Menu	To be customised	"Setting the heating curve", page 46
MAX. CIRC. B	Installer level #SECONDARY LIMITS Menu	To be customised	"Professional settings", page 50
If circuit C is a direct circuit without a flow sensor: CIRC.C⁽¹⁾	Installer level #SYSTEM Menu	DIRECT	"Setting the parameters specific to the installation", page 43
CIRC.CURVE C	Installer level #SECONDARY INSTAL.P Menu	To be customised	"Setting the heating curve", page 46

(1) The parameter is only displayed if **INSTALLATION** parameter is set to **EXTENDED**.

■ Hot water storage tank connection

QUADRO DU storage tank

In this installation example, the storage tank (type QUADRO DU) incorporates a domestic hot water zone. The boiler starts up systematically to maintain the domestic hot water zone in the storage tank or to maintain the independent tank at temperature.

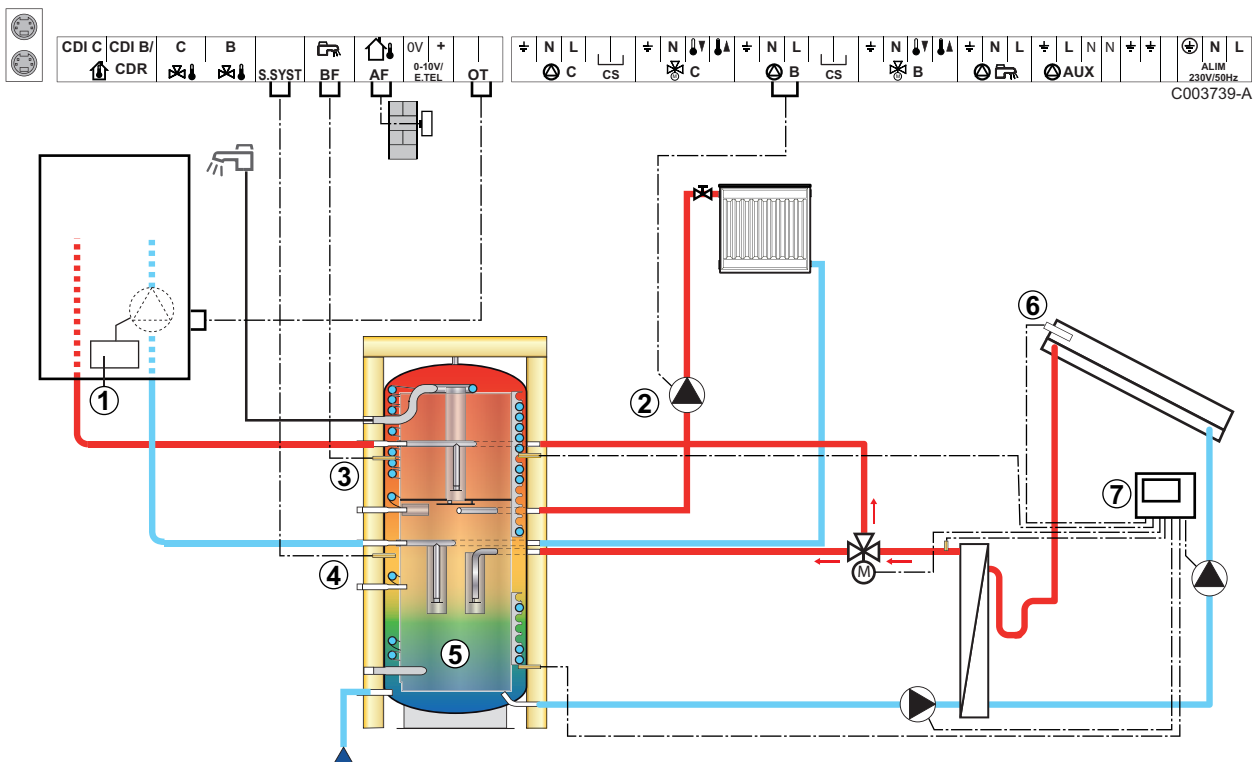

i This type of installation only works if the boiler incorporates a boiler pump managed by the boiler regulator.

- ① Boiler regulator
- ② Connect the heating pump (Circuit B).
- ③ DHW sensor
- ④ Connect the sensor from the storage tank (Package AD250).
- ⑤ Buffer tank.
- ⑥ Solar sensor probe.
- ⑦ Connect the solar station to the solar collectors.

Settings to be made for this type of installation			
Parameters	Access	Settings to be made	See chapter
INSTALLATION	Installer level #SYSTEM Menu	EXTENDED	"Displaying the parameters in extended mode", page 42
I.SYST	Installer level #SYSTEM Menu	BUFFER TANK	"Setting the parameters specific to the installation", page 43
If circuit B is a direct circuit without a flow sensor: CIRC.B ⁽¹⁾	Installer level #SYSTEM Menu	DIRECT	"Setting the parameters specific to the installation", page 43

(1) The parameter is only displayed if **INSTALLATION** parameter is set to **EXTENDED**.

i The DHW part is maintained at the DHW set point by the boiler.
 The heating zone is maintained at the set temperature calculated according to the outside temperature. The zone is reheated when the heating buffer temperature sensor ⑤ falls -6°C below the calculated set temperature. Reheating in the heating zone stops when the heating buffer temperature rises above the calculated set temperature.

■ Pool connection

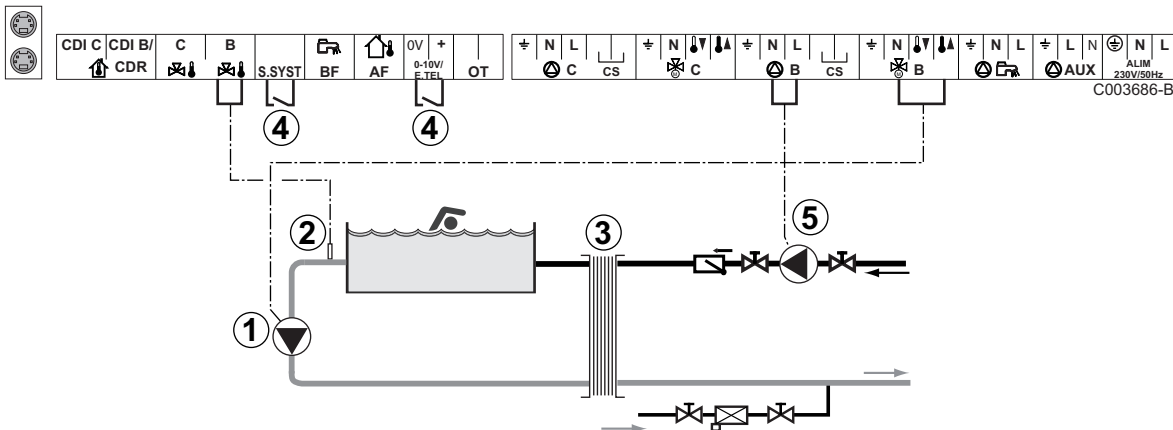

- ① Connect the secondary swimming pool pump.
- ② Connect the swimming pool sensor.

- ③ Plate heat exchanger.
- ④ Pool heating cut-off control
 - i** When the parameter **I.TEL** or **S.SYST** is set to **0/1 B**, the swimming pool is no longer heated when the contact is open (factory setting); only the antifreeze function continues to run. The contact direction can still be adjusted with parameter **CT.TEL** or **CT.SYST**.
- ⑤ Connect the primary swimming pool pump.

Settings to be made for this type of installation			
Parameters	Access	Settings to be made	See chapter
INSTALLATION	Installer level #SYSTEM Menu	EXTENDED	"Displaying the parameters in extended mode", page 42
MAX. CIRC. B	Installer level #SECONDARY LIMITS Menu	Set the value of MAX. CIRC. B to the temperature corresponding to the needs of the exchanger	"Professional settings", page 50
CIRC.B ⁽¹⁾	Installer level #SYSTEM Menu	SWIM.P.	"Setting the parameters specific to the installation", page 43
If a heating shutdown command is connected to the 0-10V inlet on the terminal block: IN 0-10V	Installer level #SYSTEM Menu	NO	"Setting the parameters specific to the installation", page 43
If a heating shutdown command is connected to the 0-10V inlet on the terminal block: I.TEL ⁽²⁾	Installer level #SYSTEM Menu	0/1 B	"Setting the parameters specific to the installation", page 43
(1) The parameter is only displayed if INSTALLATION parameter is set to EXTENDED . (2) The parameter is only displayed if the parameter IN 0-10V is set to OFF .			

Controlling the pool circuit

The control system can be used to manage a swimming pool circuit in both cases:

Case 1: The control system regulates the primary circuit (boiler/exchanger) and the secondary circuit (exchanger/pool).

- ▶ Connect the primary circuit pump (boiler/exchanger) to the pump **B** outlet. The temperature **MAX. CIRC. B** is then guaranteed during comfort periods on programme **B** in summer and winter alike.
- ▶ Connect the pool sensor (package AD212) to the **S OUTL B** input.
- ▶ Set the set point of the pool sensor using key in the range 5 - 39°C.

Case 2: The pool has already a regulation system that is to be kept. The control system only regulates the primary circuit (boiler/exchanger).

- ▶ Connect the primary circuit pump (boiler/exchanger) to the pump **B** outlet.
The temperature **MAX. CIRC. B** is then guaranteed during comfort periods on programme **B** in summer and winter alike.



The swimming pool can also be connected to circuit **C**:

- ▶ Make the connection to the terminal blocks marked **C**.
- ▶ Set the parameters for circuit **C**.

Hourly programming of the secondary circuit pump

The secondary pump operates during programme **B** comfort periods in summer and winter alike.

Stopping

To prepare your pool for winter, consult your pool specialist.

■ **Connecting a mixed tank**

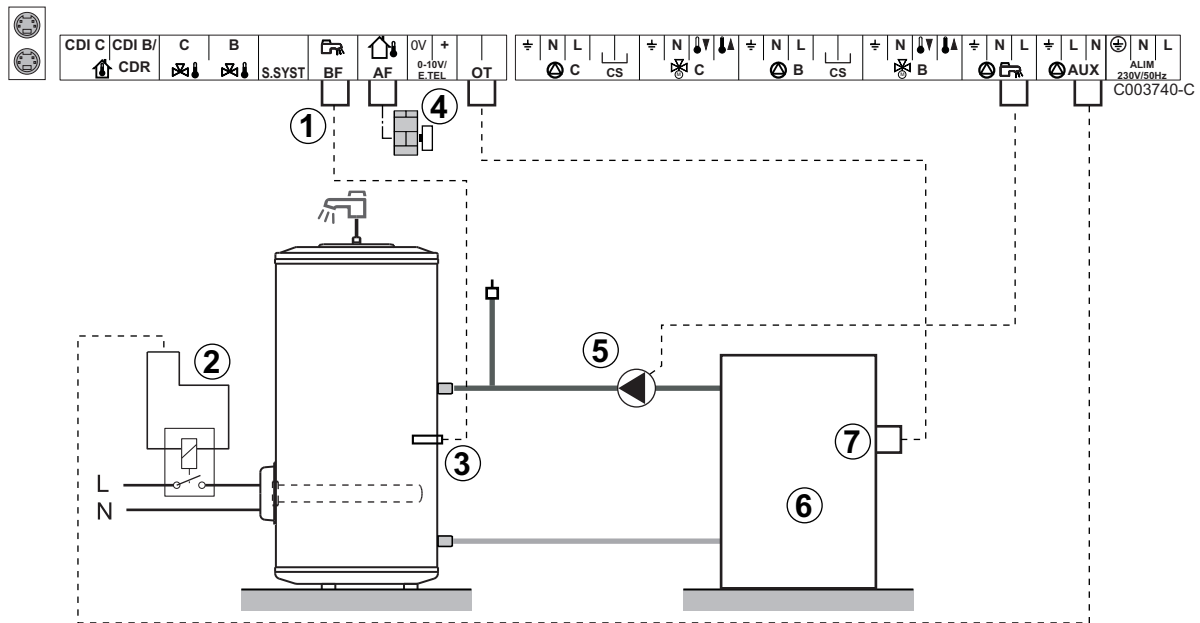

- ① Connect the electric tank
- ② Power control relay to the electrical resistor
- ③ DHW sensor
- ④ Connect the outside temperature sensor
- ⑤ D.H.W. load pump
- ⑥ Primary
- ⑦ Boiler's OT terminal block

Settings to be made for this type of installation			
Parameters	Access	Settings to be made	See chapter
INSTALLATION	Installer level #SYSTEM Menu	EXTENDED	"Displaying the parameters in extended mode", page 42
S.AUX ⁽¹⁾	Installer level #SYSTEM Menu	DHW ELEC	"Setting the parameters specific to the installation", page 43

(1) The parameter is only displayed if **INSTALLATION** parameter is set to **EXTENDED**.

■ Connecting the options

For example: TELCOM remote vocal monitoring module, remote controls for circuits **B** and **C**, second DHW tank

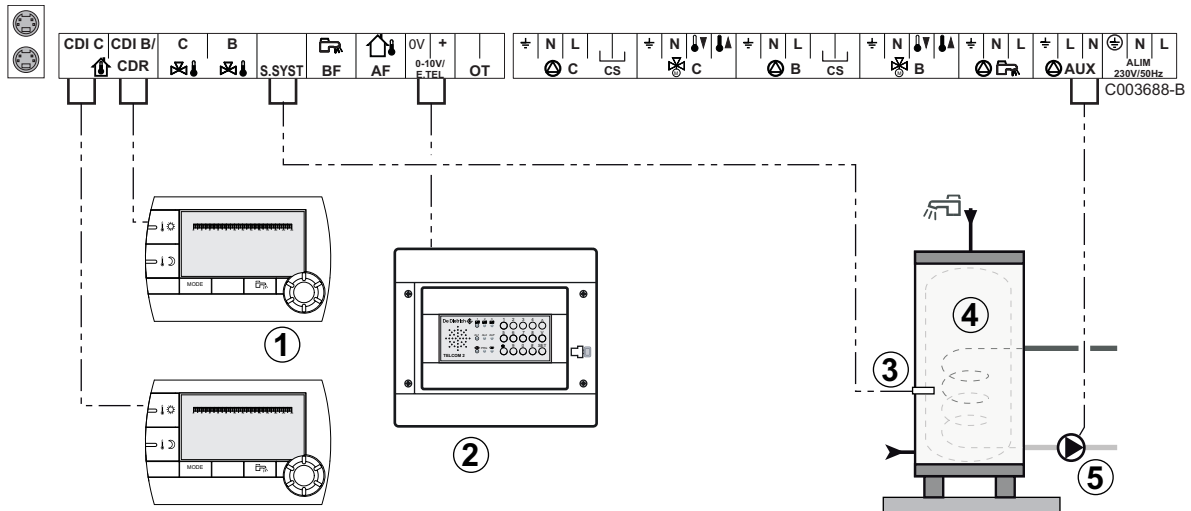

- ① Connect the remote control (Package AD258/FM52).
- ② Connect the TELCOM remote vocal monitoring module. The remote monitoring module can also be connected to the **S.SYST** inlet (if available).
- ③ Connect the DHW sensor of the second tank.
- ④ Second domestic hot water tank.
- ⑤ Connect the load pump of the second tank.

Settings to be made for this type of installation			
Parameters	Access	Settings to be made	See chapter
INSTALLATION	Installer level #SYSTEM Menu	EXTENDED	☞ "Displaying the parameters in extended mode", page 42
If second tank connected: S.AUX ⁽¹⁾	Installer level #SYSTEM Menu	DHW	☞ "Setting the parameters specific to the installation", page 43
If a remote monitoring module is connected to the 0-10V inlet on the terminal block: IN 0-10V	Installer level #SYSTEM Menu	NO	☞ "Setting the parameters specific to the installation", page 43
If a remote monitoring module is connected to the 0-10V inlet on the terminal block: I.TEL ⁽²⁾	Installer level #SYSTEM Menu	ANTIFR	☞ "Setting the parameters specific to the installation", page 43
I.SYST	Installer level #SYSTEM Menu	To be customised	☞ "Setting the parameters specific to the installation", page 43
CTC.I.SYST	Installer level #SYSTEM Menu	To be customised	☞ "Setting the parameters specific to the installation", page 43

(1) The parameter is only displayed if **INSTALLATION** parameter is set to **EXTENDED**.
 (2) The parameter is only displayed if the parameter **IN 0-10V** is set to **OFF**.

4.4.2. Cascade of boilers equipped with OTH bus

■ Boiler cascade equipped with VM iSense Pro

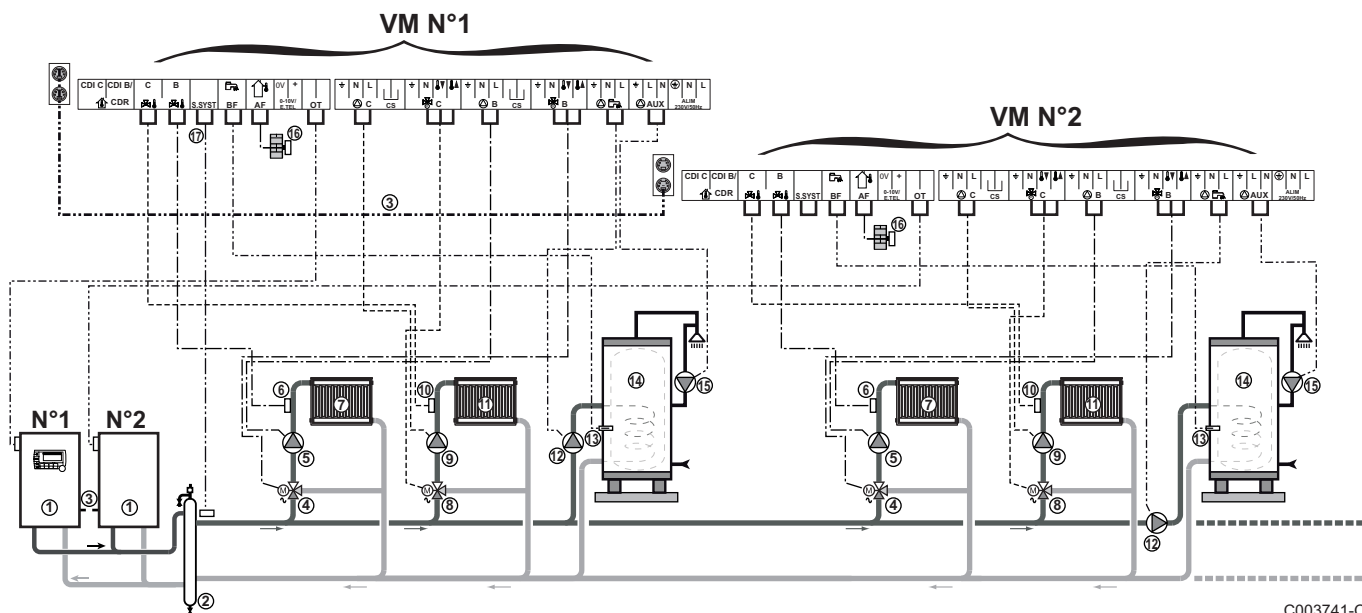

C003741-C

i DHW priority is activated on all of the system's secondary circuits.

- ① Master boiler equipped with a OpenTherm control panel
- ② Secondary boiler
- ③ Low loss header
- ④ BUS cable to make the link between boilers
- ⑤ 3 way valve circuit B
- ⑥ Heating pump circuit B
- ⑦ Outlet sensor circuit B
- ⑧ Heating circuit B
- ⑨ 3 way valve circuit C
- ⑩ Heating pump circuit C
- ⑪ Outlet sensor circuit C
- ⑫ Heating circuit C
- ⑬ D.H.W. load pump
- ⑭ DHW sensor
- ⑮ DHW storage tank
- ⑯ Domestic circulation loop pump (Optional)
- ⑰ Outside sensor (Optional)
- ⑱ System sensor



Connect a safety thermostat if the heating circuit is for underfloor heating.

Settings to be made for this type of installation: VM iSense Pro master module			
Parameters	Access	Settings to be made	See chapter
INSTALLATION	Installer level #SYSTEM Menu	EXTENDED	☞ "Displaying the parameters in extended mode", page 42
CASCADE ⁽¹⁾	Installer level #NETWORK Menu	ON	☞ "Configuring the network", page 57
MASTER CONTROLER ⁽¹⁾	Installer level #SYSTEM Menu	ON	
SYSTEM NETWORK ⁽¹⁾	Installer level #SYSTEM Menu	ADD GENE MANU	
PERMUT			

(1) The parameter is only displayed if **INSTALLATION** parameter is set to **EXTENDED**

Settings to be made for this type of installation: VM iSense Pro slave module			
Parameters	Access	Settings to be made	See chapter
INSTALLATION	Installer level #SYSTEM Menu	EXTENDED	☞ "Displaying the parameters in extended mode", page 42
CASCADE ⁽¹⁾	Installer level #NETWORK Menu	ON	☞ "Configuring the network", page 57
MASTER CONTROLER ⁽¹⁾	Installer level #SYSTEM Menu	OFF	
SLAVE NUMBER ⁽¹⁾	Installer level #SYSTEM Menu	2, 3, ...	

(1) The parameter is only displayed if **INSTALLATION** parameter is set to **EXTENDED**

■ Cascade of one boiler equipped with VM iSense Pro and one boiler equipped with an OTH Modbus interface board

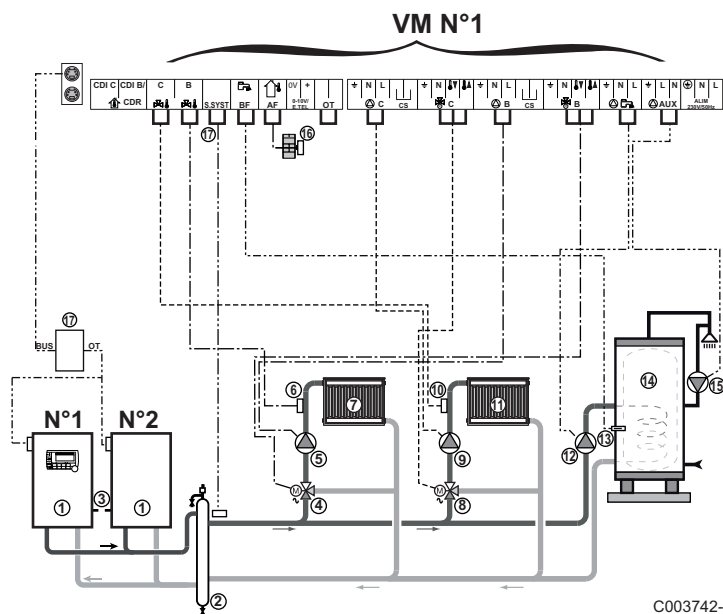

DHW priority is activated on all of the system's secondary circuits.

- ① Master boiler equipped with a OpenTherm control panel
Secondary boiler
- ② Low loss header
- ③ BUS cable to make the link between boilers
- ④ 3 way valve circuit B
- ⑤ Heating pump circuit B
- ⑥ Outlet sensor circuit B
- ⑦ Heating circuit B
- ⑧ 3 way valve circuit C
- ⑨ Heating pump circuit C
- ⑩ Outlet sensor circuit C
- ⑪ Heating circuit C
- ⑫ D.H.W. load pump
- ⑬ DHW sensor
- ⑭ DHW storage tank
- ⑮ Domestic circulation loop pump (Optional)
- ⑯ Outside sensor (Optional)
- ⑰ OTH Modbus interface board (Package AD286 / AD287)
- ⑰ System sensor



Connect a safety thermostat if the heating circuit is for underfloor heating.

Settings to be made for this type of installation: VM iSense Pro master module			
Parameters	Access	Settings to be made	See chapter
INSTALLATION	Installer level #SYSTEM Menu	EXTENDED	"Displaying the parameters in extended mode", page 42
CASCADE ⁽¹⁾	Installer level #NETWORK Menu	ON	"Configuring the network", page 57
MASTER CONTROLLER ⁽¹⁾	Installer level #SYSTEM Menu	ON	
SYSTEM NETWORK ⁽¹⁾	Installer level #SYSTEM Menu	ADD SLAVE	
PERMUT			

(1) The parameter is only displayed if **INSTALLATION** parameter is set to **EXTENDED**

Settings to be made for this type of installation: VM iSense Pro slave module			
Parameters	Access	Settings to be made	See chapter
INSTALLATION	Installer level #SYSTEM Menu	EXTENDED	"Displaying the parameters in extended mode", page 42
CASCADE ⁽¹⁾	Installer level #NETWORK Menu	ON	"Configuring the network", page 57
MASTER CONTROLLER ⁽¹⁾	Installer level #SYSTEM Menu	OFF	
SLAVE NUMBER ⁽¹⁾	Installer level #SYSTEM Menu	2, 3, ...	

(1) The parameter is only displayed if **INSTALLATION** parameter is set to **EXTENDED**

4.5 Installation and connection examples - Appliance set to 0/1+V3V

4.5.1. Independent control system

■ 1 mixed heating circuit

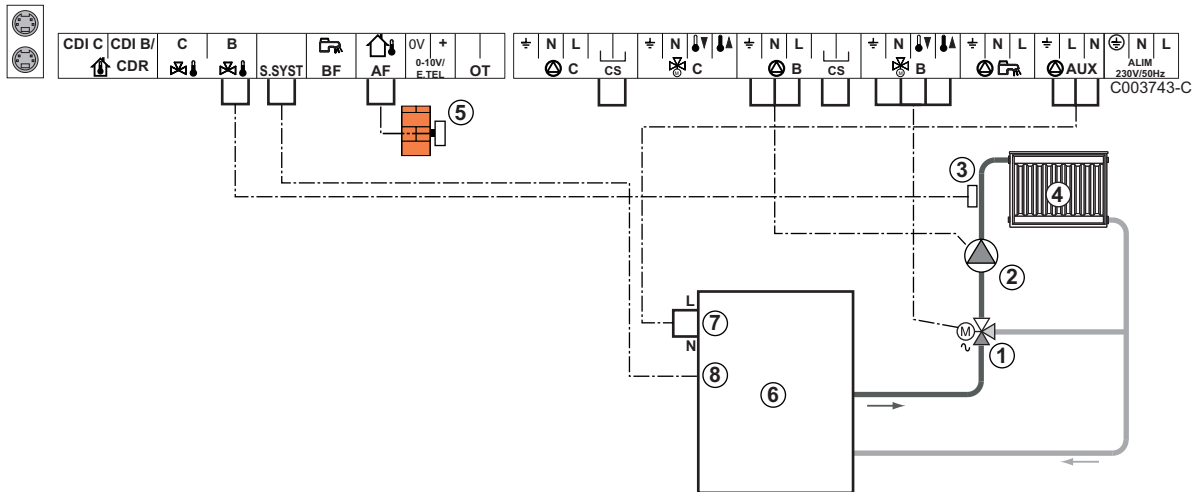

- ① 3 way valve circuit B
- ② Heating pump circuit B
- ③ Outlet sensor circuit B
- ④ Heating circuit B
- ⑤ Outside sensor
- ⑥ Boiler
- ⑦ Boiler control at 230 V
- ⑧ System sensor used as boiler sensor



CAUTION

The VM iSense Pro module does not fulfil the boiler's overheating safety functions.



- ▶ Earth the various pumps and 3-way valves.
- ▶ Connect a safety thermostat if the heating circuit is for underfloor heating.

Settings to be made for this type of installation			
Parameters	Access	Settings to be made	See chapter
CIRC.CURVE B	Installer level #SECONDARY INSTAL.PRE P.INSTAL} Menu	To be customised	"Setting the heating curve", page 46
MAX. CIRC. B	Installer level #SECONDARY LIMITS Menu	To be customised	"Professional settings", page 50

■ 2 mixed heating circuits and 1 DHW circuit

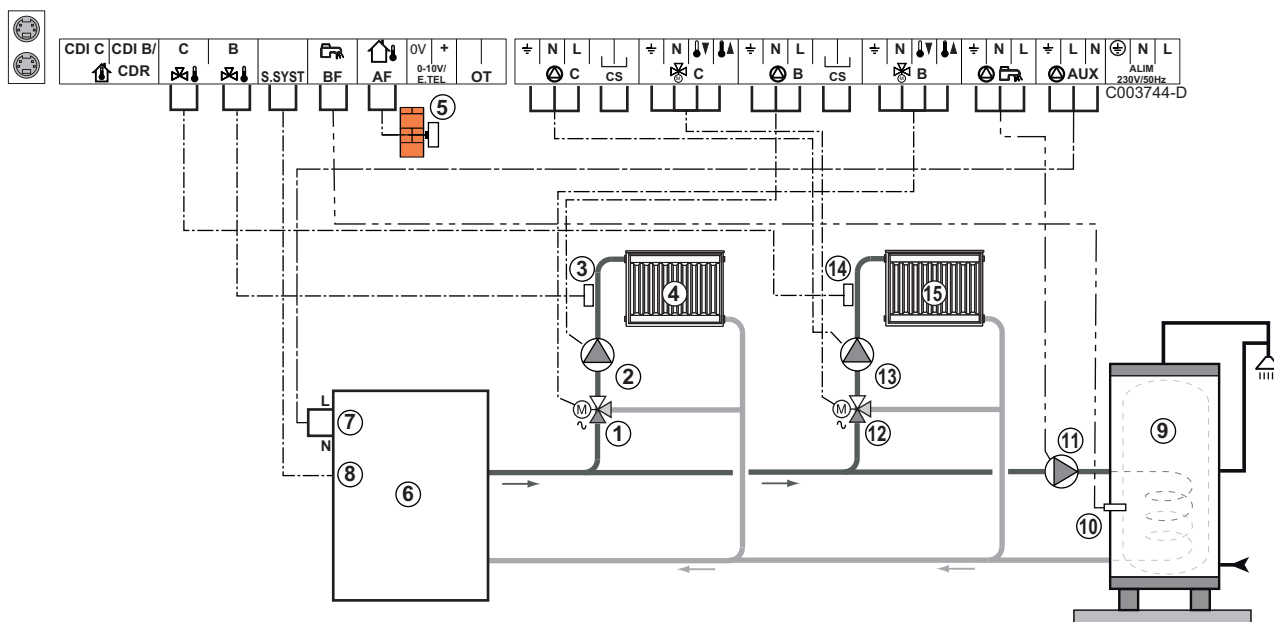

- ① 3 way valve circuit B
- ② Heating pump circuit B
- ③ Outlet sensor circuit B
- ④ Heating circuit B
- ⑤ Outside sensor
- ⑥ Boiler
- ⑦ Boiler control at 230 V
- ⑧ System sensor used as boiler sensor
- ⑨ DHW storage tank
- ⑩ DHW sensor
- ⑪ D.H.W. load pump
- ⑫ 3 way valve circuit C
- ⑬ Heating pump circuit C
- ⑭ Outlet sensor circuit C
- ⑮ Heating circuit C



CAUTION

The VM iSense Pro module does not fulfil the boiler's overheating safety functions.



- ▶ Earth the various pumps and 3-way valves.
- ▶ Connect a safety thermostat if the heating circuit is for underfloor heating.

Settings to be made for this type of installation			
Parameters	Access	Settings to be made	See chapter
CIRC.CURVE B	Installer level #SECONDARY INSTAL.P Menu	To be customised	"Setting the heating curve", page 46
MAX. CIRC. B	Installer level #SECONDARY LIMITS Menu	To be customised	"Professional settings", page 50
CIRC.CURVE C	Installer level #SECONDARY INSTAL.P Menu	To be customised	"Setting the heating curve", page 46
MAX. CIRC. C	Installer level #SECONDARY LIMITS Menu	To be customised	"Professional settings", page 50

■ 1 direct heating circuit + 1 mixed heating circuit + 1 DHW circuit

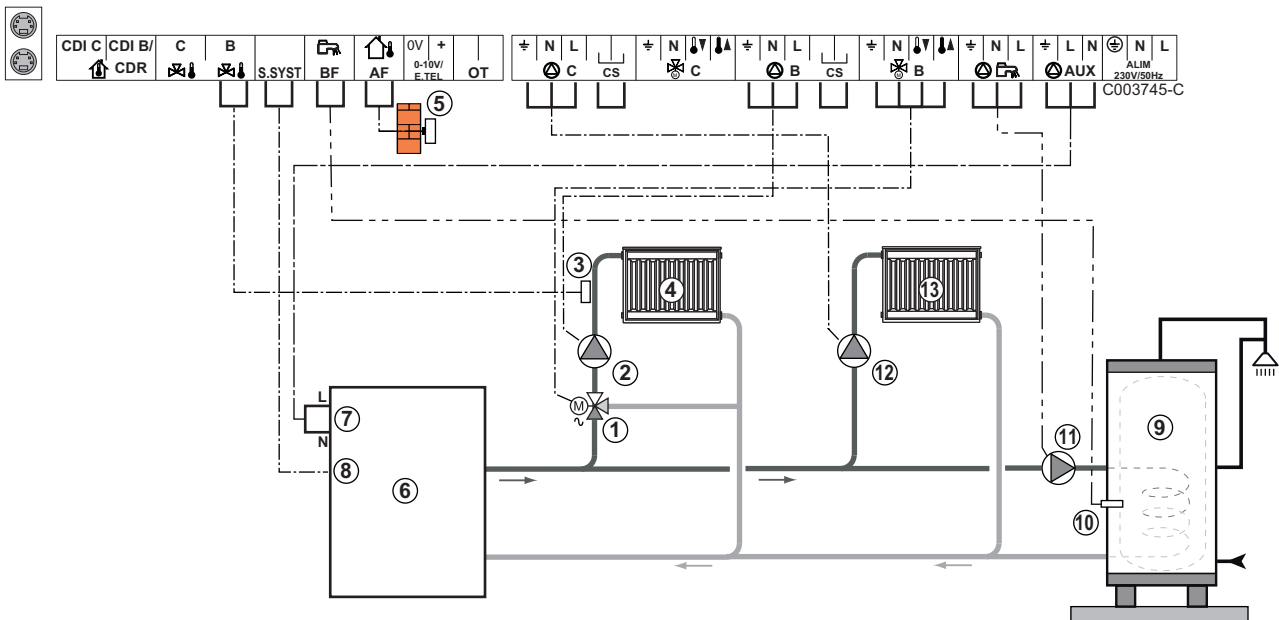

- ① 3 way valve circuit B
- ② Heating pump circuit B
- ③ Outlet sensor circuit B
- ④ Heating circuit B
- ⑤ Outside sensor
- ⑥ Boiler
- ⑦ Boiler control at 230 V
- ⑧ System sensor used as boiler sensor
- ⑨ DHW storage tank
- ⑩ DHW sensor
- ⑪ D.H.W. load pump
- ⑫ Heating pump circuit C

13 Heating circuit C



CAUTION

The VM iSense Pro module does not fulfil the boiler's overheating safety functions.



- ▶ Earth the various pumps and 3-way valves.
- ▶ Connect a safety thermostat if the heating circuit is for underfloor heating.

Settings to be made for this type of installation			
Parameters	Access	Settings to be made	See chapter
INSTALLATION	Installer level #SYSTEM Menu	EXTENDED	"Displaying the parameters in extended mode", page 42
CIRC.CURVE B	Installer level #SECONDARY INSTAL.P Menu	To be customised	"Setting the heating curve", page 46
MAX. CIRC. B	Installer level #SECONDARY LIMITS Menu	To be customised	"Professional settings", page 50
If circuit C is a direct circuit without a flow sensor: CIRC.C⁽¹⁾	Installer level #SYSTEM Menu	DIRECT	"Setting the parameters specific to the installation", page 43
CIRC.CURVE C	Installer level #SECONDARY INSTAL.P Menu	To be customised	"Setting the heating curve", page 46

(1) The parameter is only displayed if **INSTALLATION** parameter is set to **EXTENDED**.

■ Pool connection

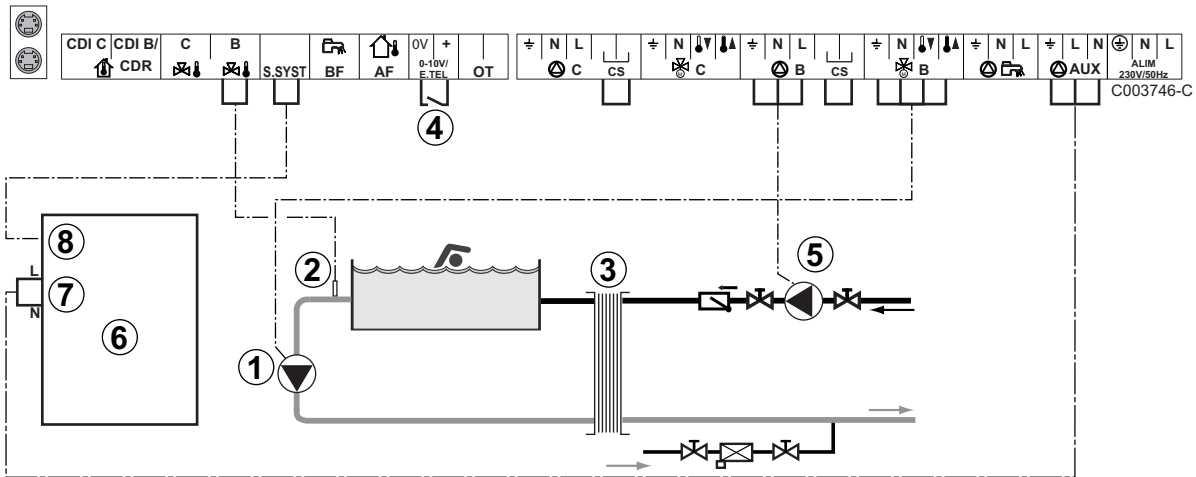

- ① Connect the secondary swimming pool pump.
- ② Connect the swimming pool sensor.
- ③ Plate heat exchanger.

- ④ Pool heating cut-off control
 - i** When the parameter **I.TEL** is on **0/1 BR B}**, the swimming pool is no longer heated when the contact is open (factory setting), only the antifreeze continues to be active. The contact direction can still be adjusted by the parameter **CT.TEL**.
- ⑤ Connect the primary swimming pool pump.
- ⑥ Boiler
- ⑦ Boiler control at 230 V
- ⑧ System sensor used as boiler sensor



CAUTION

The VM iSense Pro module does not fulfil the boiler's overheating safety functions.

Settings to be made for this type of installation			
Parameters	Access	Settings to be made	See chapter
INSTALLATION	Installer level #SYSTEM Menu	EXTENDED	"Displaying the parameters in extended mode", page 42
MAX. CIRC. B	Installer level #SECONDARY LIMITS Menu	Set the value of MAX. CIRC. B to the temperature corresponding to the needs of the exchanger	"Professional settings", page 50
CIRC.B ⁽¹⁾	Installer level #SYSTEM Menu	SWIM.P.	"Setting the parameters specific to the installation", page 43
If a heating shutdown command is connected to the 0-10V inlet on the terminal block: IN 0-10V	Installer level #SYSTEM Menu	NO	"Setting the parameters specific to the installation", page 43
If a heating shutdown command is connected to the 0-10V inlet on the terminal block: I.TEL ⁽²⁾	Installer level #SYSTEM Menu	0/1 B	"Setting the parameters specific to the installation", page 43
(1) The parameter is only displayed if INSTALLATION parameter is set to EXTENDED . (2) The parameter is only displayed if the parameter IN 0-10V is set to OFF .			

Controlling the pool circuit

The control system can be used to manage a swimming pool circuit in both cases:

Case 1: The control system regulates the primary circuit (boiler/exchanger) and the secondary circuit (exchanger/pool).

- ▶ Connect the primary circuit pump (boiler/exchanger) to the pump **B** outlet. The temperature **MAX. CIRC. B** is then guaranteed during comfort periods on programme **B** in summer and winter alike.
- ▶ Connect the pool sensor (package AD212) to the **S OUTL B** input.
- ▶ Set the set point of the pool sensor using key in the range 5 - 39°C.

Case 2: The pool has already a regulation system that is to be kept. The control system only regulates the primary circuit (boiler/exchanger).

- ▶ Connect the primary circuit pump (boiler/exchanger) to the pump **B** outlet.
The temperature **MAX. CIRC. B** is then guaranteed during comfort periods on programme **B** in summer and winter alike.



The swimming pool can also be connected to circuit **C**:

- ▶ Make the connection to the terminal blocks marked **C**.
- ▶ Set the parameters for circuit **C**.

Hourly programming of the secondary circuit pump

The secondary pump operates during programme **B** comfort periods in summer and winter alike.

Stopping



To prepare your pool for winter, consult your pool specialist.

■ **Connecting the options**

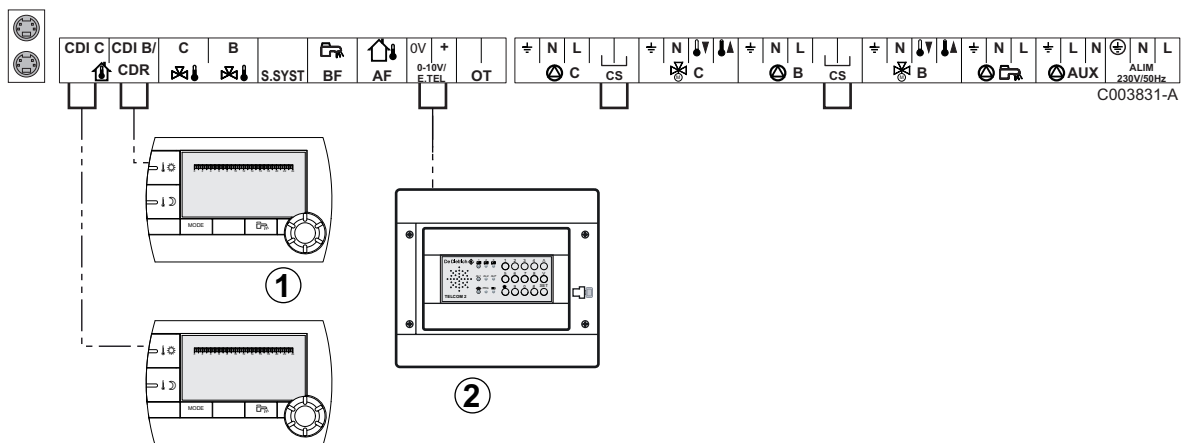
For example: TELCOM remote vocal monitoring module, remote controls for circuits **B** and **C**, second DHW tank



- ① Connect the remote control (Package AD258/FM52).
- ② Connect the TELCOM remote vocal monitoring module.

Settings to be made for this type of installation			
Parameters	Access	Settings to be made	See chapter
INSTALLATION	Installer level #SYSTEM Menu	EXTENDED	 "Displaying the parameters in extended mode", page 42
If a remote monitoring module is connected to the 0-10V inlet on the terminal block: IN 0-10V	Installer level #SYSTEM Menu	NO	 "Setting the parameters specific to the installation", page 43
If a remote monitoring module is connected to the 0-10V inlet on the terminal block: I.TEL⁽¹⁾	Installer level #SYSTEM Menu	ANTIFR	 "Setting the parameters specific to the installation", page 43

(1) The parameter is only displayed if the parameter **IN 0-10V** is set to **OFF**.

4.5.2. Slave control system in cascade

■ Connecting 2 x 2 valve circuits and a DHW tank

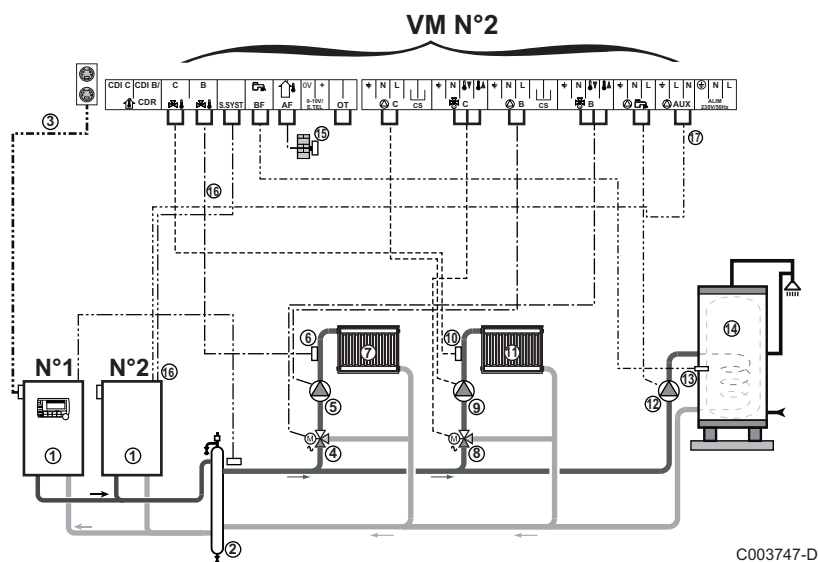



C003747-D

 DHW priority is activated on all of the system's secondary circuits.

- ① Master boiler equipped with a Diematic 3 / Diematic m3 / iSense Pro control panel
- Secondary boiler
- ② Low loss header
- ③ BUS cable
- ④ 3 way valve circuit B
- ⑤ Heating pump circuit B
- ⑥ Outlet sensor circuit B
- ⑦ Heating circuit B
- ⑧ 3 way valve circuit C

- ⑨ Heating pump circuit C
- ⑩ Outlet sensor circuit C
- ⑪ Heating circuit C
- ⑫ D.H.W. load pump
- ⑬ DHW sensor
- ⑭ DHW storage tank
- ⑮ Outside sensor (Optional)
- ⑯ System sensor used as boiler sensor
- ⑰ Boiler control at 230 V

Settings to be made for this type of installation: VM iSense Pro slave module			
Parameters	Access	Settings to be made	See chapter
INSTALLATION	Installer level #SYSTEM Menu	EXTENDED	 "Displaying the parameters in extended mode", page 42
CASCADE ⁽¹⁾	Installer level #NETWORK Menu	ON	 "Configuring the network", page 57
MASTER CONTROLER ⁽¹⁾	Installer level #SYSTEM Menu	OFF	
SLAVE NUMBER ⁽¹⁾	Installer level #SYSTEM Menu	2, 3, ...	

(1) The parameter is only displayed if **INSTALLATION** parameter is set to **EXTENDED**

4.6 Electrical connection diagram

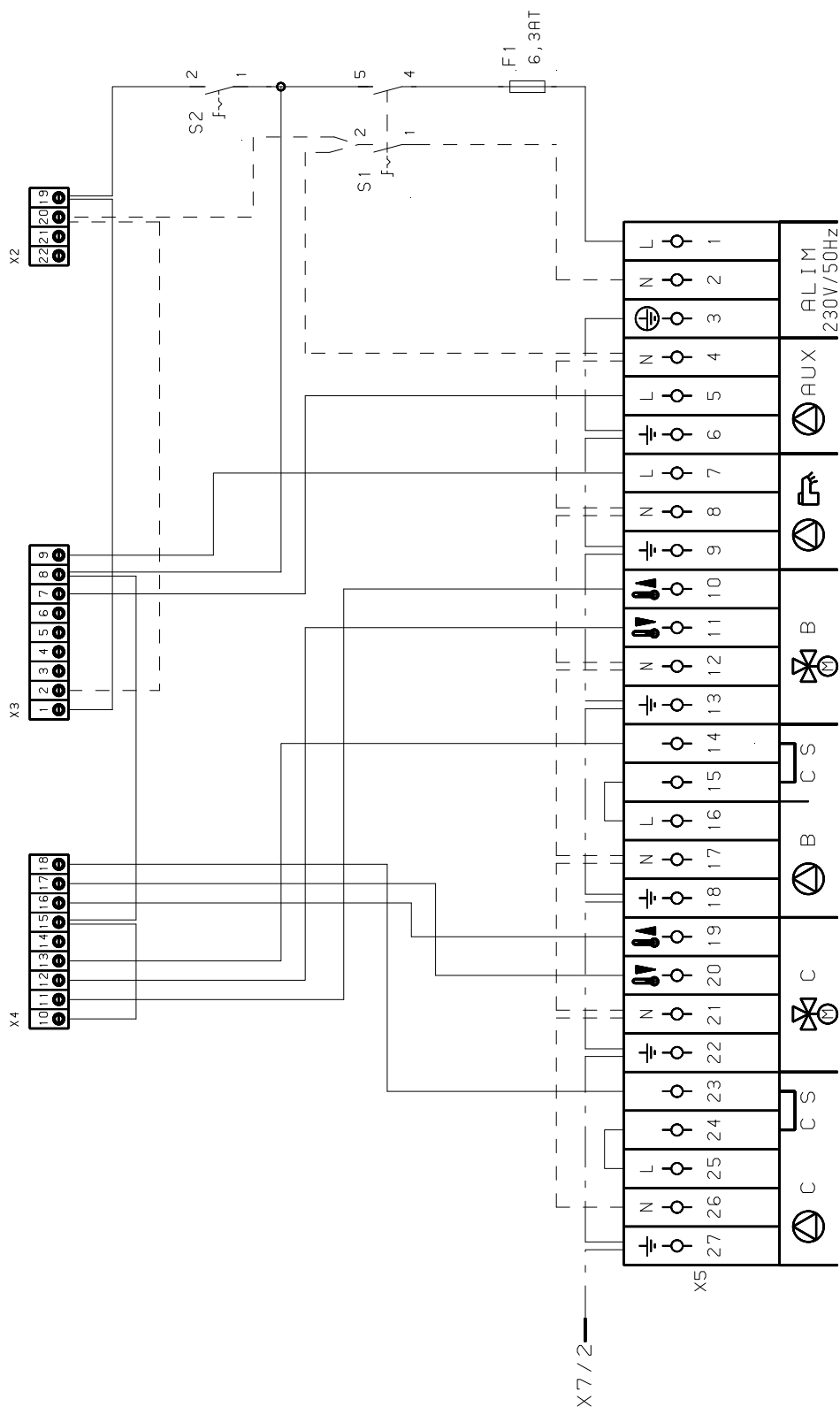

M002856-A

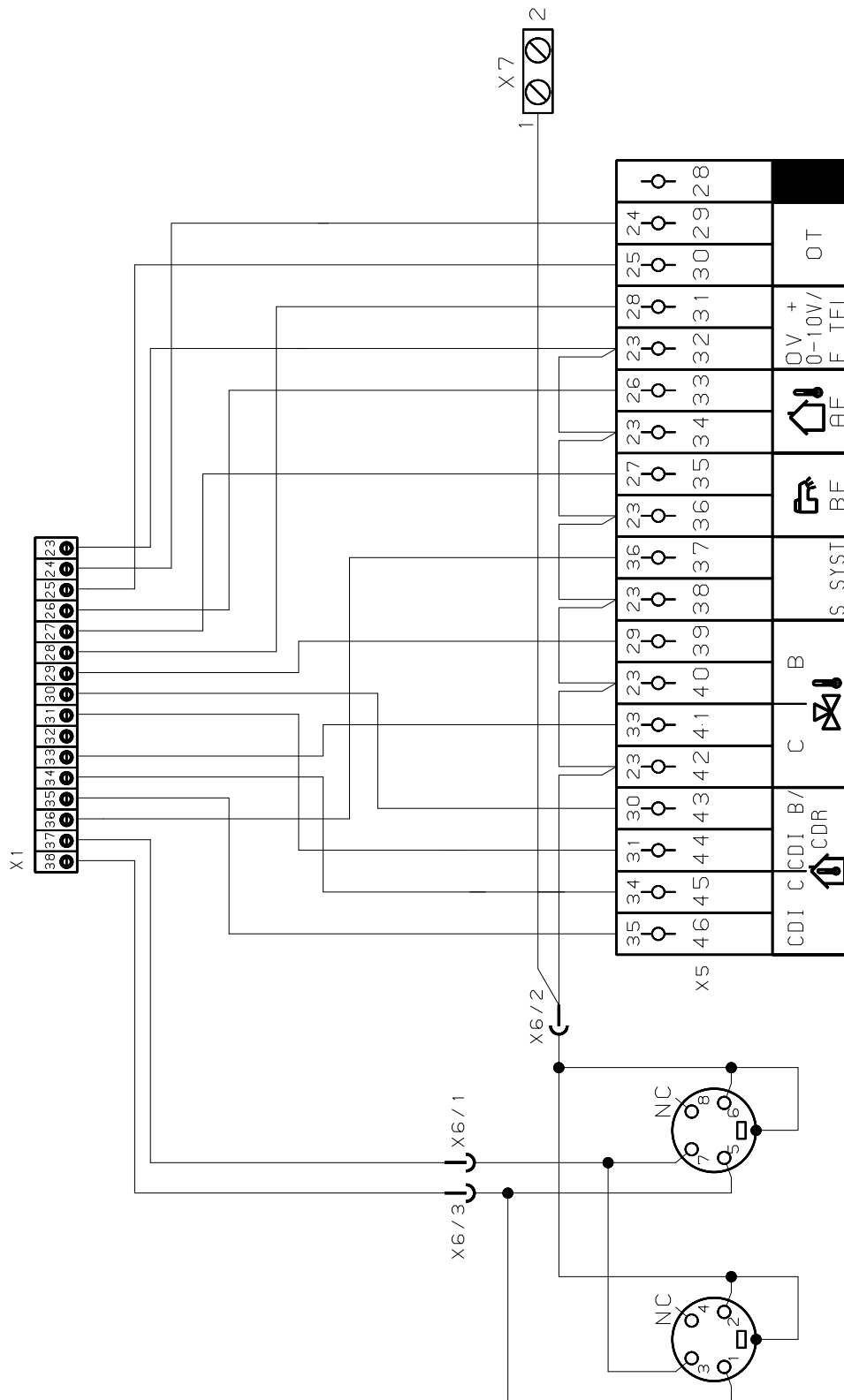

M002855-A

5 Operating the appliance

5.1 Powering up for the first time

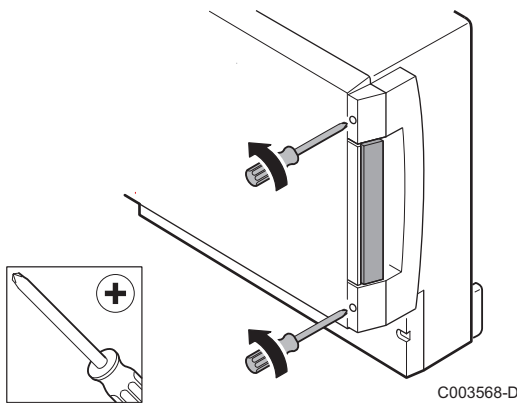
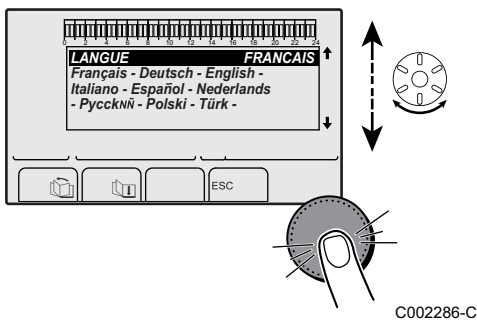
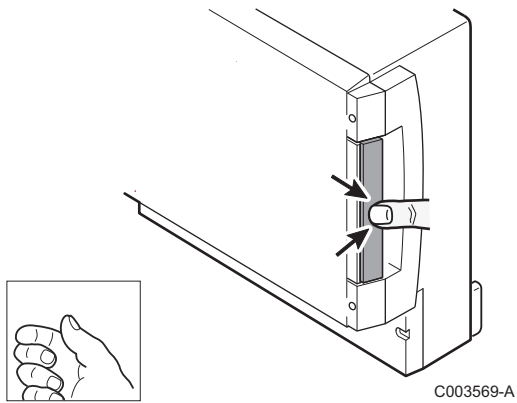

1. Press the spring-loaded tab to open the protective cover.
2. Press button **ON**.
3. Press button **AUTO**.
4. The first time the boiler is powered up, the **LANGUAGE** menu is displayed. Select the desired language by turning the rotary button.
5. To confirm, press the rotary button.
6. Set parameter **CONFIGURATION**. Select the desired setting:

Setting	Description
VM/MR	Operation with all Diematic control systems - No DHW priority. If CONFIGURATION parameter is set to VM/MR: <ol style="list-style-type: none"> 1. Press key  for around 5 seconds. 2. Select the menu #SYSTEM. 3. Set the parameter INSTALLATION to EXTENDED. 4. Select the menu #NETWORK. 5. Select the parameter VM NUMBER. 6. Assign a code (from 20 to 39) to the appliance. The codes assigned to the devices must always be done in increasing order starting with 20 and without omitting any numbers. Never assign the same code to 2 different VM iSense Pro control systems.
3WV+	Operation with Diematic-m 3 - iSense Pro control systems - DHW priority available.
0/1+V3V	Control for an ON/OFF generator
OTH+3WV	Control for a generator by BUS OpenTherm

7. To confirm, press the rotary button.
8. Insert the 2 screws (provided in the documentation bag) at the front of the module to guarantee protection rating IP21.

5.2 Access to the various browsing levels

5.2.1. User level

The information and settings in the User level can be accessed by everyone.

1. Press the → key.

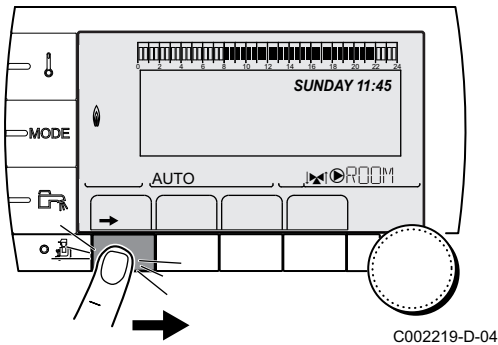



5.2.2. Installer level

The information and settings in the Installer level can be accessed by experienced people.

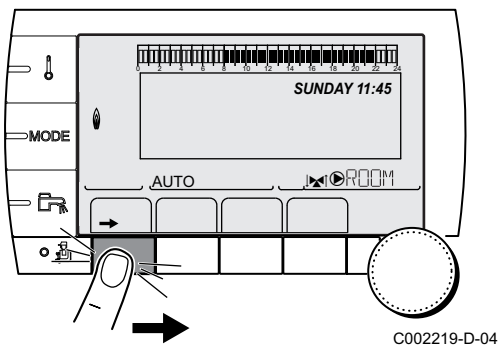
1. Press the → key.



2. Press the  key.

 It is also possible to access the installer level by pressing only the  key for around 5 seconds.

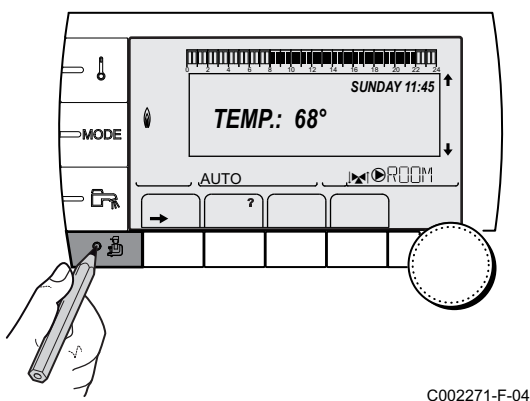

5.2.3. After Sales level

The After Sales Service information and settings can be accessed by the professional providing the After Sales Service.

1. Press the → key.

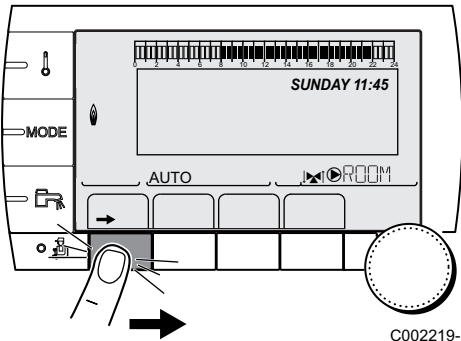

C002219-D-04

2. Press key  for around 5 seconds.



It is also possible to access the After Sales level by pressing only the  key for around 10 seconds.

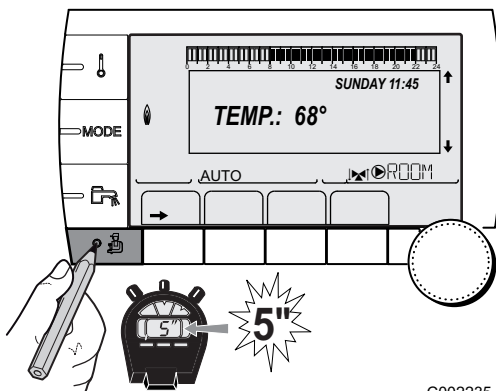

C002235-F-04

5.3 Browsing in the menus

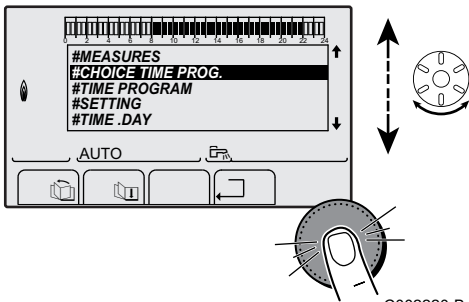

C002220-B-04

1. To select the desired menu, turn the rotary button.
2. To access the menu, press the rotary button.
To go back to the previous display, press the key .

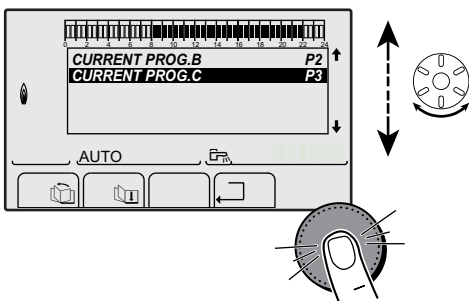

C002221-C-04

3. To select the desired parameter, turn the rotary button.
4. To modify the parameter, press the rotary button.
To go back to the previous display, press the key .

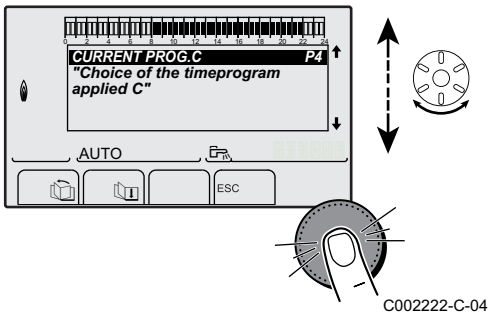

5. To modify the parameter, turn the rotary button.
6. To confirm, press the rotary button.

i To cancel, press key **ESC**.

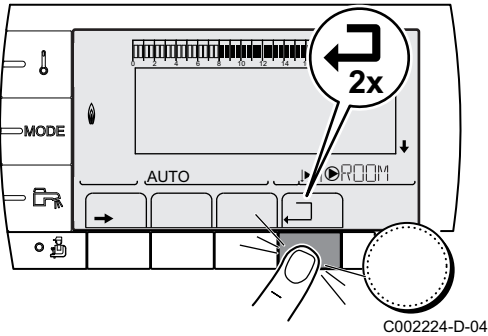

7. To go back to the main display, press key **□** 2 times.

i It is possible to use the and keys instead of the rotary button.

5.4 Reading out measured values

The various values measured by the appliance are displayed in the **#MEASURES** menu.

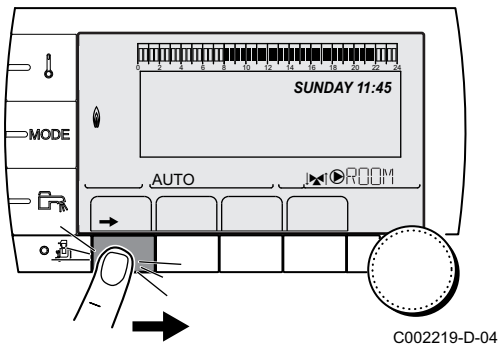

1. To access user level: Press the **→** key.
2. Select the menu **#MEASURES**.

i

- ▶ Turn the rotary button to scroll through the menus or modify a value.
- ▶ Press the rotary button to access the selected menu or confirm a value modification.

For a detailed explanation of menu browsing, refer to the chapter: "Browsing in the menus", page 40.

User level - #MEASURES menu		
Parameter	Description	Unit
OUTSIDE TEMP.	Outside temperature	°C
ROOMTEMP.B (1)	Room temperature of circuit B	°C
ROOMTEMP.C (1)	Room temperature of circuit C	°C
BOILER TEMP (2)	Water temperature in the boiler	°C
WATER TEMP. (1)	Water temperature in the DHW tank	°C
STOR.TANK.TEMP (1)	Water temperature in the storage tank	°C
SWIMMING P.T.B (1)	Water temperature of the swimming pool on circuit B	°C
SWIMMING P.T.C (1)	Water temperature of the swimming pool on circuit C	°C
OUTLET TEMP.B (1)	Temperature of the flow water in circuit B	°C

(1) The parameter is only displayed for the options, circuits or sensors actually connected.
 (2) According to the configuration

User level - #MEASURES menu		
Parameter	Description	Unit
OUTLET TEMP.C (1)	Temperature of the flow water in circuit C	°C
TEMP.SYSTEM (1)	Temperature of the system flow water if multi-generator	°C
T.DHW BOTTOM (1)	Water temperature in the bottom of the DHW tank	°C
TEMP.TANK AUX (1)	Water temperature in the second DHW tank connected to the AUX circuit	°C
TEMP.SOL.TANK (1)(2)	Temperature of the hot water produced by solar power (TS)	°C
SOLAR.COLL.T. (1) (2)	Solar panel temperature (TC)	°C
SOLA.ENERGY (1) (2)	Solar energy accumulated in the tank	kWh
IN 0-10V (1)(2)	Voltage at input 0-10 V	V
CTRL	Software control number	

(1) The parameter is only displayed for the options, circuits or sensors actually connected.
 (2) According to the configuration

5.5 Settings after powering up for the first time

5.5.1. Displaying the parameters in extended mode

The display mode on the control panel is set as standard in such a way as only to show the conventional parameters. It is possible to switch to extended mode by proceeding as follows:

1. Access the installer level: Press key  for around 5 seconds.
2. Select the menu **#SYSTEM**.

-  Turn the rotary button to scroll through the menus or modify a value.
- ▶ Press the rotary button to access the selected menu or confirm a value modification.

 For a detailed explanation of menu browsing, refer to the chapter: "Browsing in the menus", page 40

3. Set parameter **INSTALLATION** to **EXTENDED**.

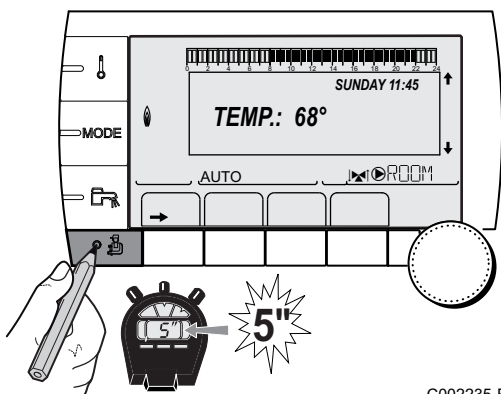

C002235-F-04

Installer level - #SYSTEM Menu				
Parameter	Adjustment range	Description	Factory setting	Customer setting
INSTALLATION	TRADITIONAL	Displays the parameters of a conventional installation	TRADITIONAL	
	EXTENDED	Displays all parameters		

-  Regardless of what is done to the keys, the regulator switches back to **TRADITIONAL** mode after 30 minutes.

5.5.2. Setting the parameters specific to the installation

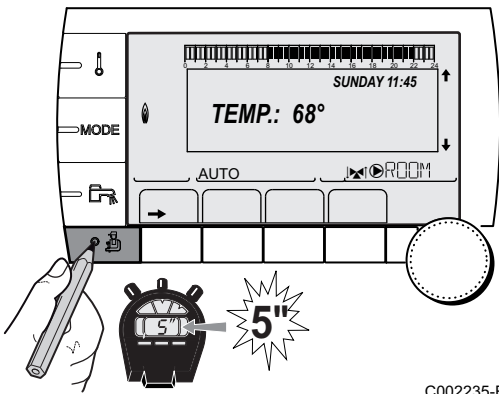

C002235-F-04

1. Access the installer level: Press key for around 5 seconds.
2. Select the menu **#SYSTEM**.



- ▶ Turn the rotary button to scroll through the menus or modify a value.
- ▶ Press the rotary button to access the selected menu or confirm a value modification.

For a detailed explanation of menu browsing, refer to the chapter: "Browsing in the menus", page 40

3. Set the following parameters according to the connections made to the PCBs:

Installer level - #SYSTEM menu				
Parameter	Adjustment range	Description	Factory setting	Customer setting
CIRC.B ⁽¹⁾	3WV	Connecting a circuit with 3-way valve (For example: Underfloor heating)	3WV	
	SWIM.P.	Using the circuit for pool management		
	DIRECT	Use of circuit in direct heating circuit Check and set the heating curve if necessary. See chapter: "Setting the heating curve", page 46		
CIRC.C ⁽¹⁾	3WV	Connecting a circuit with 3-way valve (For example: Underfloor heating)	3WV	
	SWIM.P.	Using the circuit for pool management		
	DIRECT	Use of circuit in direct heating circuit Check and set the heating curve if necessary. See chapter: "Setting the heating curve", page 46		
S.AUX ⁽¹⁾	DHW LOOP	Use as a domestic loop pump	DHW LOOP	
	PROGRAM.	Use as an independent programmable outlet		
	PRIMARY PUMP	The outlet AUX is active if a heating demand is present on the secondary pump		
	DHW	Use of primary circuit of second DHW tank		
	FAILURE	The outlet AUX is active if an fault is detected		
	DHW ELEC	Used to control the electrical resistor according to the timer programme on circuit AUX in summer mode.		
CTC.I.SYST ⁽²⁾	CLOSE	See table below.	CLOSE	
	Open			

(1) The parameter is only displayed if **INSTALLATION** is set to **EXTENDED**
 (2) According to the configuration
 (3) The parameter is only displayed if **CONFIGURATION** is set to **OTH+3WV**
 (4) The parameter is only displayed if **IN 0-10V** is set to **OFF**

Installer level - #SYSTEM menu				
Parameter	Adjustment range	Description	Factory setting	Customer setting
I.SYST ⁽¹⁾	SYSTEM ⁽²⁾	The inlet sensor is used to connect the common flow sensor of a cascade system	SYSTEM	
	BUFFER TANK ⁽²⁾	Hot water storage tank affected to heating only		
	DHW STRAT ⁽²⁾⁽³⁾	Using the DHW tank with 2 sensors (top and bottom)		
	ST.TANK+DHW ⁽²⁾	Hot water storage tank affected to heating and domestic hot water		
	ANTIFR	Boiler anti-freeze activation		
	0/1 B	ON or OFF contact: I.SYST can be used as an antifreeze activation inlet on circuit B		
	0/1 C	ON or OFF contact: I.SYST can be used as an antifreeze activation inlet on circuit C		
	0/1 DHW	ON or OFF contact: I.SYST can be used as an antifreeze activation inlet on circuit ECS		
	0/1 AUX ⁽²⁾	ON or OFF contact: I.SYST can be used as an antifreeze activation inlet on circuit AUX. When I.SYST is not active, the auxiliary circuit (AUX) follows the maximum boiler temperature (parameter BOILER MAX).		
CT.TEL ⁽¹⁾	CLOSE	See table below.	CLOSE	
	Open			
I.TEL ⁽¹⁾⁽⁴⁾	ANTIFR	Boiler anti-freeze activation	ANTIFR	
	0/1 B	ON or OFF contact: I.TEL can be used as an antifreeze activation inlet on circuit B		
	0/1 C	ON or OFF contact: I.TEL can be used as an antifreeze activation inlet on circuit C		
	0/1 DHW	ON or OFF contact: I.TEL can be used as an antifreeze activation inlet on circuit ECS		
	0/1 AUX ⁽²⁾	ON or OFF contact: I.TEL can be used as an antifreeze activation inlet on circuit AUX. When I.TEL is not active, the auxiliary circuit (AUX) follows the maximum boiler temperature (parameter BOILER MAX).		
IN 0-10V ⁽²⁾	OFF	The 0-10V inlet on the terminal block can be used as a telephone inlet.	OFF	
	ON	Activating the 0-10 V function		

(1) The parameter is only displayed if **INSTALLATION** is set to **EXTENDED**
 (2) According to the configuration
 (3) The parameter is only displayed if **CONFIGURATION** is set to **OTH+3WV**
 (4) The parameter is only displayed if **IN 0-10V** is set to **OFF**

Influence of the parameter setting CT.TEL on the I.TEL contact			
CT.TEL	I.TEL	I.TEL contact closed	I.TEL contact open
CLOSE	ANTIFR	The antifreeze mode is active on all boiler circuits.	The mode selected on the boiler is active.
	0/1 B	The mode selected on the circuit is active.	The antifreeze mode is active on the circuit concerned.
	0/1 C	The mode selected on the circuit is active.	The antifreeze mode is active on the circuit concerned.
	0/1 DHW	The mode selected on the DHW circuit is active.	The antifreeze mode is active for the DHW circuit.
	0/1 AUX	<ul style="list-style-type: none"> ▶ The AUX outlet on the connection terminal block is active. ▶ The boiler operates at a setpoint temperature equal to BOILER MAX. 	<ul style="list-style-type: none"> ▶ The AUX outlet on the connection terminal block is not active. ▶ The boiler operates with a setpoint temperature as a function of the outside temperature.

Influence of the parameter setting CT.TEL on the I.TEL contact			
CT.TEL	I.TEL	I.TEL contact closed	I.TEL contact open
Open	ANTIFR	The mode selected on the boiler is active.	The antifreeze mode is active on all boiler circuits.
	0/1 B	The antifreeze mode is active on the circuit concerned.	The mode selected on the circuit is active.
	0/1 C	The antifreeze mode is active on the circuit concerned.	The mode selected on the circuit is active.
	0/1 DHW	The antifreeze mode is active for the DHW circuit.	The mode selected on the DHW circuit is active.
	0/1 AUX	<ul style="list-style-type: none"> ▶ The ►AUX outlet on the connection terminal block is not active. ▶ The boiler operates with a setpoint temperature as a function of the outside temperature. 	<ul style="list-style-type: none"> ▶ The ►AUX outlet on the connection terminal block is active. ▶ The boiler operates at a setpoint temperature equal to BOILER MAX.

Influence of the parameter setting CTC.I.SYST on the I.SYST contact			
CTC.I.SYST	I.SYST	I.SYST contact closed	I.SYST contact open
CLOSE	ANTIFR	The antifreeze mode is active on all boiler circuits.	The mode selected on the boiler is active.
	0/1 B	The mode selected on the circuit is active.	The antifreeze mode is active on the circuit concerned.
	0/1 C	The mode selected on the circuit is active.	The antifreeze mode is active on the circuit concerned.
	0/1 DHW	The mode selected on the DHW circuit is active.	The antifreeze mode is active for the DHW circuit.
	0/1 AUX	<ul style="list-style-type: none"> ▶ The ►AUX outlet on the connection terminal block is active. ▶ The boiler operates at a setpoint temperature equal to BOILER MAX. 	<ul style="list-style-type: none"> ▶ The ►AUX outlet on the connection terminal block is not active. ▶ The boiler operates with a setpoint temperature as a function of the outside temperature.
Open	ANTIFR	The mode selected on the boiler is active.	The antifreeze mode is active on all boiler circuits.
	0/1 B	The antifreeze mode is active on the circuit concerned.	The mode selected on the circuit is active.
	0/1 C	The antifreeze mode is active on the circuit concerned.	The mode selected on the circuit is active.
	0/1 DHW	The antifreeze mode is active for the DHW circuit.	The mode selected on the DHW circuit is active.
	0/1 AUX	<ul style="list-style-type: none"> ▶ The ►AUX outlet on the connection terminal block is not active. ▶ The boiler operates with a setpoint temperature as a function of the outside temperature. 	<ul style="list-style-type: none"> ▶ The ►AUX outlet on the connection terminal block is active. ▶ The boiler operates at a setpoint temperature equal to BOILER MAX.

5.5.3. Naming the circuits and generators

1. Access the installer level: Press key  for around 5 seconds.
2. Select the menu **#NAMES OF THE CIRCUITS.**



- ▶ Turn the rotary button to scroll through the menus or modify a value.
- ▶ Press the rotary button to access the selected menu or confirm a value modification.

 For a detailed explanation of menu browsing, refer to the chapter: "Browsing in the menus", page 40

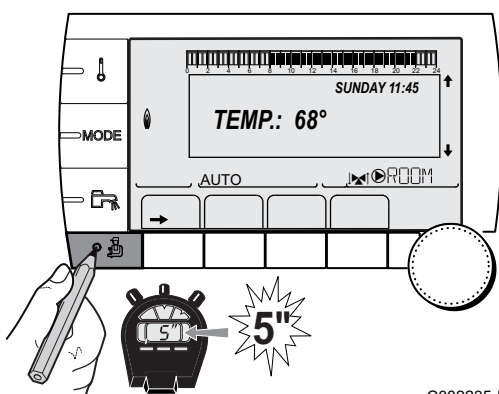

C002235-F-04

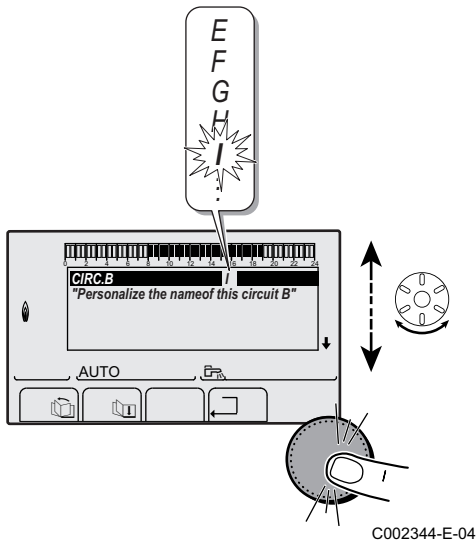

3. Select the circuit or generator you wish to rename.

Installer level - #NAMES OF THE CIRCUITS menu		
Parameter	Description	Name given by the customer
CIRC.B	Circuit B	
CIRC.C	Circuit C	
CIRC.AUX	Auxiliary circuit	
CIRC.DHW	Domestic hot water circuit	
GENE	Generator	

- Turn the rotary button to choose the first character from the list. To confirm, press the rotary button.
- Then press again to enter a second character or turn the rotary button to leave an empty space.
- Choose the other characters in the same way. The input zone may contain up to 6 characters.

i To move from one character to another, turn the rotary button. To exit without modifications, press key **ESC**.

- To confirm the name, press the rotary button and then turn the button slightly anti-clockwise. When the symbol ← appears, press the rotary button. The name is confirmed.

i If the name reaches 6 characters, it is automatically confirmed when the last character is confirmed.

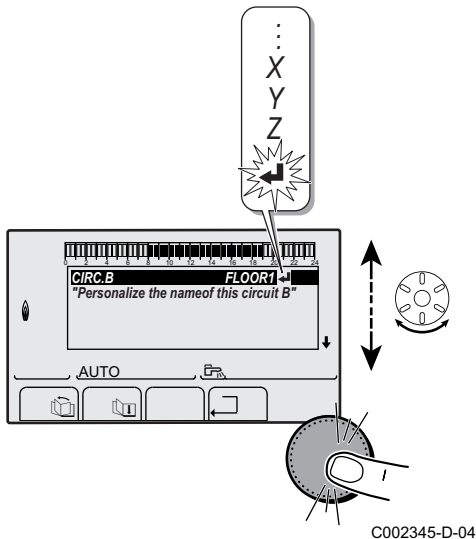

5.5.4. Setting the heating curve

- Access the installer level: Press key **⏏** for around 5 seconds.
- Select the menu **#SECONDARY INSTAL.P.**

- i**
- Turn the rotary button to scroll through the menus or modify a value.
 - Press the rotary button to access the selected menu or confirm a value modification.

👉 For a detailed explanation of menu browsing, refer to the chapter: "Browsing in the menus", page 40.

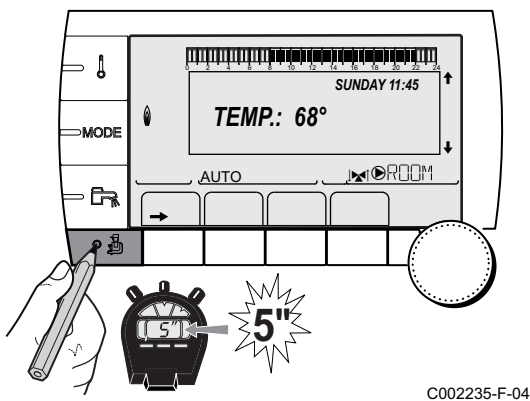

3. Select the parameter **CIRC.CURVE ...**

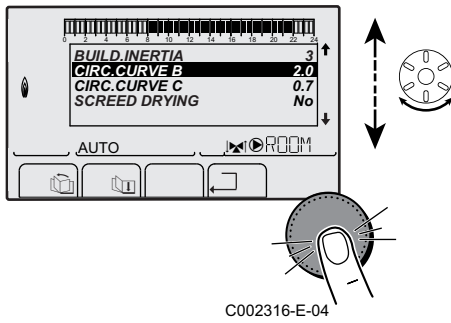

4. To modify the value directly, turn the rotary button.
To modify the value by displaying the curve, press key μA .

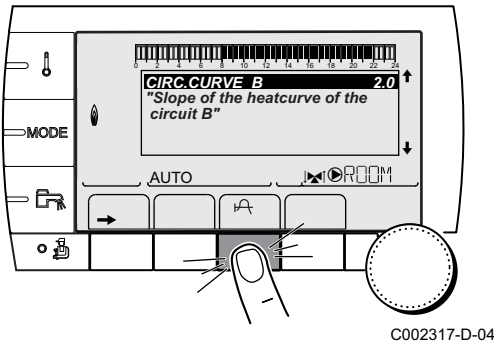

5. To modify the curve, turn the rotary button.
6. To confirm, press the rotary button.
To cancel, press key **ESC**.

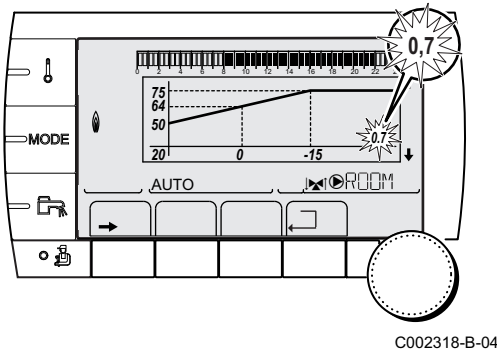

i 0.7 = Heating curve set.

■ Heating curve without BCT

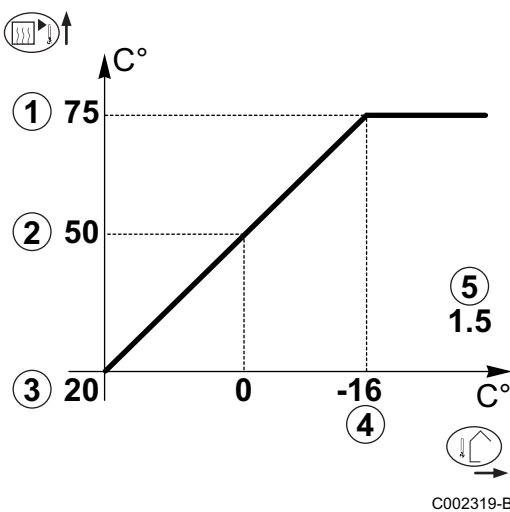

- ① Maximum temperature of the circuit
- ② Water temperature in the circuit for an outside temperature of 0°C
- ③ **DAY** set point on the circuit
- ④ Outside temperature for which the maximum water temperature in the circuit is reached
- ⑤ Value of the heating curve
Select the parameter **CIRC.CURVE ..**

i When you modify the heating curve, ② and ④ are recalculated and repositioned automatically.

■ Heating curve with BCT

The **BCT** (Base heat Curve Temperature) parameter allows a minimum operating temperature to be imposed on the heating circuit (this temperature may be constant if the circuit gradient is nil).

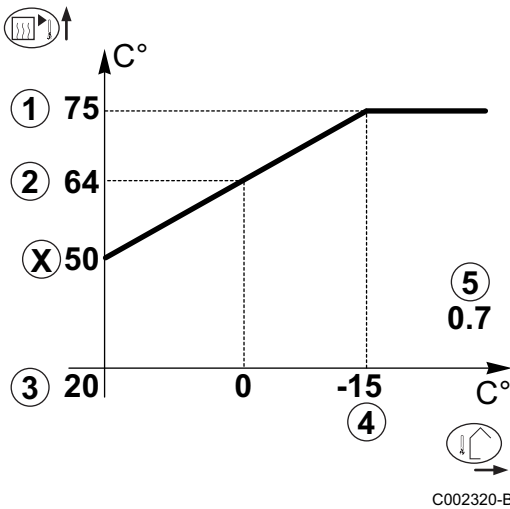

- ① Maximum temperature of the circuit
- ② Water temperature in the circuit for an outside temperature of 0°C
- ③ **DAY** set point on the circuit
- ④ Outside temperature for which the maximum water temperature in the circuit is reached
- ⑤ Value of the heating curve
Select the parameter **CIRC.CURVE ..**
- x Value set to the parameter **HCZP D**

i When you modify the heating curve, ② and ④ are recalculated and repositioned automatically.

C002320-B

5.6 Changing the settings

The module is set for the most common heating systems. With these settings, practically all heating systems operate correctly. The user or installer can optimise the parameters according to own preferences.

i For the user settings, refer to the user instructions.

5.6.1. Language selection

1. Access the installer level: Press key **i** for around 5 seconds.
2. Select the menu **#LANGUAGE**.

- i** Turn the rotary button to scroll through the menus or modify a value.
- Press the rotary button to access the selected menu or confirm a value modification.

i For a detailed explanation of menu browsing, refer to the chapter: "Browsing in the menus", page 40

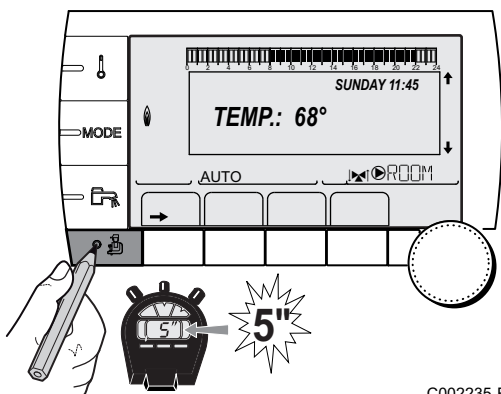

C002235-F-04

Installer level - #LANGUAGE Menu	
Adjustment range	Description
FRANCAIS	Display in French
DEUTSCH	Display in German
ENGLISH	Display in English
ITALIANO	Display in Italian
ESPANOL	Display in Spanish
NEDERLANDS	Display in Dutch
POLSKI	Display in Polish
РУССКИЙ	Display in Russian
TÜRK	Display in Turkish

5.6.2. Defining the configuration mode

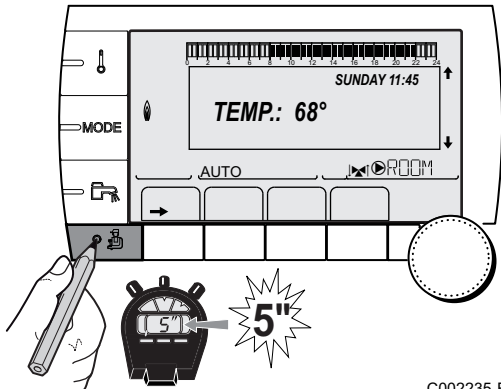

C002235-F-04

1. Access the installer level: Press key  for around 5 seconds.
2. Select the menu **#SYSTEM**.



- ▶ Turn the rotary button to scroll through the menus or modify a value.
- ▶ Press the rotary button to access the selected menu or confirm a value modification.

 For a detailed explanation of menu browsing, refer to the chapter: "Browsing in the menus", page 40

3. Set parameter **CONFIGURATION**:

Installer level - #SYSTEM menu			
Parameter	Adjustment range	Description	Customer setting
CONFIGURATION	VM/MR	Operation with all Diematic control systems - No DHW priority. If CONFIGURATION parameter is set to VM/MR: 1. Select the menu #NETWORK . 2. Select the parameter VM NUMBER . 3. Assign a code (from 20 to 39) to the appliance. The codes assigned to the devices must always be done in increasing order starting with 20 and without omitting any numbers. Never assign the same code to 2 different VM iSense Pro control systems.	
	3WV+	Operation with Diematic-m 3 - iSense Pro control systems - DHW priority available.	
	0/1+V3V	Control for an ON/OFF generator	
	OTH+3WV	Control for a generator by BUS OpenTherm	

5.6.3. Calibrating the sensors

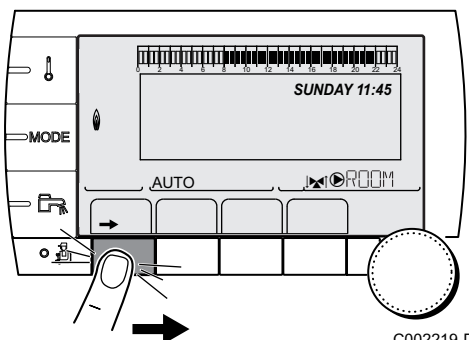

C002219-D-04

1. To access user level: Press the → key.
2. Select the menu **#SETTING**.



- ▶ Turn the rotary button to scroll through the menus or modify a value.
- ▶ Press the rotary button to access the selected menu or confirm a value modification.

 For a detailed explanation of menu browsing, refer to the chapter: "Browsing in the menus", page 40

3. Set the following parameters:

User level - #SETTING menu				
Parameter	Adjustment range	Description	Factory setting	Customer setting
SUM/WIN	15 to 30 °C	Used to set the outside temperature above which heating will be shut down. <ul style="list-style-type: none"> ▶ The heating pumps are shut down. ▶ Domestic hot water continues to be produced. ▶ The symbol ☰ appears. 	22 °C	
	NO	Heating is never shut down automatically		
CALIBR.OUT		Outside sensor calibration: Used to correct the outside temperature	Outside temperature	
CALIBR.ROOM B ⁽¹⁾⁽²⁾ (3)		Calibration of the room sensor on circuit B Make this setting 2 hours after switching on, when the room temperature has stabilised	Room temperature of circuit B	
OFFSET ROOM B ⁽¹⁾⁽⁴⁾ (3)	-5.0 to +5.0 °C	Room offset on circuit B: Is used to set a room offset Make this setting 2 hours after switching on, when the room temperature has stabilised	0.0	
ANTIFR.ROOM B ⁽¹⁾⁽²⁾⁽³⁾	0.5 to 20 °C	Room temperature at which the antifreeze mode is activated on circuit B	6 °C	
CALIBR.ROOM C ⁽¹⁾⁽²⁾ (3)		Calibration of the room sensor on circuit C Make this setting 2 hours after switching on, when the room temperature has stabilised	Room temperature of circuit C	
OFFSET ROOM C ⁽¹⁾⁽⁴⁾ (3)	-5.0 to +5.0 °C	Room offset on circuit C: Is used to set a room offset Make this setting 2 hours after switching on, when the room temperature has stabilised	0.0	
ANTIFR.ROOM C ⁽¹⁾⁽²⁾⁽³⁾	0.5 to 20 °C	Room temperature antifreeze activation on circuit C	6 °C	

(1) The parameter is only displayed if **INSTALLATION** parameter is set to **EXTENDED**
 (2) The parameter is only displayed if a room sensor is connected to the circuit concerned
 (3) The parameter is only displayed if the circuit concerned is actually connected
 (4) The parameter is only displayed if no room sensor is connected to the circuit concerned or the sensor has no influence

5.6.4. Professional settings

1. Access the installer level: Press key  for around 5 seconds.
2. Set the following parameters:



- ▶ Turn the rotary button to scroll through the menus or modify a value.
- ▶ Press the rotary button to access the selected menu or confirm a value modification.

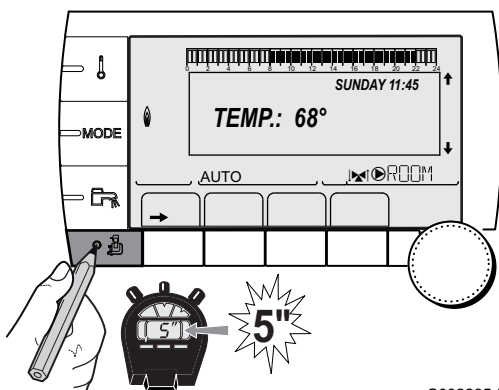

 For a detailed explanation of menu browsing, refer to the chapter: "Browsing in the menus", page 40.







C002235-F-04

Installer level - #PRIMARY LIMITS menu ⁽¹⁾				
Parameter	Adjustment range	Description	Factory setting	Customer setting
BOILER MAX ⁽¹⁾	40 to 90 °C	Maximum temperature authorised by the boiler	90 °C	
BOILER MIN ⁽¹⁾	10 to 50 °C	Minimum temperature authorised by the boiler	20 °C	







(1) According to the configuration

Installer level - #SECONDARY LIMITS menu				
Parameter	Adjustment range	Description	Factory setting	
MAX.CIRC.B	20 to 95 °C	Maximum temperature (Circuit B)  "MAX.CIRC...", page 54	50 °C	
MAX.CIRC.C	20 to 95 °C	Maximum temperature (Circuit C)  "MAX.CIRC...", page 54	50 °C	
OUT.ANTIFREEZE	OFF , -8 to +10 °C	Outside temperature at which the installation's antifreeze protection is activated. Below this temperature the pumps are permanently on and the minimum temperatures for each circuit are respected. When NIGHT : STOP is set, the reduced temperature is maintained in each circuit (#SECONDARY INSTAL.P menu). OFF : Antifreeze protection is not activated	+3 °C	
HCZP D B ⁽¹⁾⁽²⁾	OFF , 20 to 90 °C	Curve base temperature in Daytime mode (Circuit B)	OFF	
HCZP N B ⁽¹⁾⁽²⁾	OFF , 20 to 90 °C	Curve base temperature in Nighttime mode (Circuit B)	OFF	
HCZP D C ⁽¹⁾⁽²⁾	OFF , 20 to 90 °C	Curve base temperature in Daytime mode (Circuit C)	OFF	
HCZP N C ⁽¹⁾⁽²⁾	OFF , 20 to 90 °C	Curve base temperature in Nighttime mode (Circuit C)	OFF	
PRIM.TEMP.DHW ⁽¹⁾	50 to 95 °C	Set point temperature if domestic hot water production	80 °C	

(1) The parameter is only displayed if **INSTALLATION** parameter is set to **EXTENDED**
(2) The parameter can be set to the heating curve by pressing key .

Installer level - #SECONDARY INSTAL.P menu				
Parameter	Adjustment range	Description	Factory setting	Customer setting
BUILD.INERTIA ⁽¹⁾	0 (10 hours) to 10 (50 hours)	Characterisation of building's inertia: 0 for a building with low thermal inertia. 3 for a building with normal thermal inertia. 10 for a building with high thermal inertia. Modification of the factory setting is only useful in exceptional cases.	3 (22 hours)	
CIRC.CURVE B ⁽²⁾	0 to 4	Heating curve of the circuit B  "CIRC.CURVE ..", page 54	0.7	
ANTICIP.B	0.0 to 10.0	Activation and adjustment of the anticipation time  "ANTICIP.B, ANTICIP.C ", page 54	NO	
ROOM INFL.B ⁽¹⁾	0 to 10	Influence of room sensor B  "ROOM S.INFL", page 55	3	

(1) The parameter is only displayed if **INSTALLATION** parameter is set to **EXTENDED**
(2) The parameter can be set to the heating curve by pressing key 
(3) The parameter is only displayed if **SCREED DRYING** is other than **OFF**
(4) According to the configuration
(5) The parameter is only displayed if **IN 0-10V** is set to **ON**.
(6) If a reversal valve is connected, DHW priority will always be total regardless of the setting.

Installer level - #SECONDARY INSTAL.P menu				
Parameter	Adjustment range	Description	Factory setting	Customer setting
CIRC.CURVE C⁽²⁾	0 to 4	Heating curve of the circuit C  "CIRC.CURVE ..", page 54	0.7	
ANTICIP.C	0.0 to 10.0	Activation and adjustment of the anticipation time  "ANTICIP.B, ANTICIP.C ", page 54	NO	
ROOM INFL.C⁽¹⁾	0 to 10	Influence of room sensor C  "ROOM S.INFL", page 55	3	
SCREED DRYING	NO, B, C, B+C	Drying the floor  "SCREED DRYING", page 54	NO	
START DRYING TEMP⁽³⁾	20 to 50 °C	Scree drying start temperature	20 °C	
STOP DRYING TEMP⁽³⁾	20 to 50 °C	Scree drying stop temperature	20 °C	
NB DAYS DRYING⁽³⁾	0 to 99		0	
NIGHT⁽¹⁾	DEC.	The lower temperature is maintained (Night mode)  "NIGHT", page 55	DEC.	
	STOP	The boiler is stopped (Night mode)  "NIGHT", page 55		
IN 0-10V⁽⁴⁾	OFF / TEMPERATURE	Activating the 0-10 V function  "Function 0-10 V", page 56	OFF	
VMIN/OFF 0-10V⁽¹⁾⁽⁵⁾	0 to 10 V	Voltage corresponding to the instruction set minimum	0.5 V	
VMAX 0-10V⁽¹⁾⁽⁵⁾	0 to 10 V	Voltage corresponding to the instruction set maximum	10 V	
CONS.MIN 0-10V⁽¹⁾⁽⁵⁾	5 to 100 °C	Instruction minimum set temperature	100 °C	
CONS.MAX 0-10V⁽¹⁾⁽⁵⁾	5 to 100 °C	Maximum set temperature	100 °C	
BAND WIDTH⁽¹⁾	4 to 16 K	Control unit bandwidth for the 3-way valves. Option of increasing the bandwidth if the valves are rapid or of reducing it if they are slow.	12 K	
BOIL/3WV SHIFT⁽¹⁾	0 to 16 K	Minimum temperature difference between the boiler and the valves	4 K	
H.PUMP DELAY⁽¹⁾	0 to 15 minutes	Timing of the shutdown of the heating pumps. The timing of heating pump shutdown prevents the boiler overheating.	4 minutes	
DHW.PUMP DELAY⁽¹⁾	0 to 15 minutes	Timing of the shutdown of the domestic hot water pump. The timing of the domestic hot water load pump shutdown prevents the boiler and the heating circuits overheating (Only if a load pump is used).	2 minutes	

(1) The parameter is only displayed if **INSTALLATION** parameter is set to **EXTENDED**
(2) The parameter can be set to the heating curve by pressing key \curvearrowright
(3) The parameter is only displayed if **SCREED DRYING** is other than **OFF**
(4) According to the configuration
(5) The parameter is only displayed if **IN 0-10V** is set to **ON**.
(6) If a reversal valve is connected, DHW priority will always be total regardless of the setting.

Installer level - #SECONDARY INSTAL.P menu				
Parameter	Adjustment range	Description	Factory setting	Customer setting
ADAPT	ON	Automatic adaptation of the heating curves for each circuit with a room sensor with an influence of >0.	ON	
	OFF	The heating curves can only be modified manually.		
PRIORITY DHW⁽⁶⁾	TOTAL	Interruption of pool heating and reheating during domestic hot water production.	TOTAL	
	SLIDING	Domestic hot water production and heating on the valve circuits if the available output is sufficient and the hydraulic connection allows.		
	NO	Heating and domestic hot water production in parallel if the hydraulic connection allows. ⚠ Risk of overheating in the direct circuit.		
LEG PROTEC		The anti legionella function acts to prevent the development of legionella in the dhw tank, these bacteria are responsible for legionellosis.	OFF	
	OFF	Antilegionella function not activated		
	DAILY	The tank is overheated every day from 4:00 o'clock to 5:00 o'clock		
	WEEKLY	The tank is overheated every Saturday from 4:00 o'clock to 5:00 o'clock		

(1) The parameter is only displayed if **INSTALLATION** parameter is set to **EXTENDED**
(2) The parameter can be set to the heating curve by pressing key \updownarrow
(3) The parameter is only displayed if **SCREED DRYING** is other than **OFF**
(4) According to the configuration
(5) The parameter is only displayed if **IN 0-10V** is set to **ON**.
(6) If a reversal valve is connected, DHW priority will always be total regardless of the setting.

Installer level - #SUN Menu ⁽¹⁾				
Parameter	Adjustment range	Description	Factory setting	Customer setting
DEC.SOLAR DHW	0 to 30 °C	Maximum drop in the DHW set point when the solar pump is running at 100%	5°C	
REFERENCE DT	10 to 20 °C	Temperature difference that the solar pump tries to maintain between the solar DHW sensor and the panel	10°C	
MAX.T.COLLECTOR	100 to 125 °C	Temperature of the panel above which the solar pump starts up. The pump does not operate if the temperature of the solar tank is higher than 80°C	100°C	
MAX TPS PUMP	1 to 5 min	Minimum operating duration of the solar pump at 100% on start-up	1 minute	
MIN.PUMP SPEED	50 to 100 %	Minimum speed of the solar pump	50%	
TUBE COLLECTOR	YES / NO	Set to YES if tubular collectors are used	NO	
MAX FLOW	0 to 20 l/min	Maximum flow rate of the solar pump  "MAX FLOW" , page 56	6.7 l/mim.	

(1) The menu is only displayed if the solar control system is connected and the **INSTALLATION** parameter is set to **EXTENDED**

■ **MAX.CIRC...**



WARNING

If using underfloor heating, do not modify the factory setting (50 °C). To install this, please consult existing legislation.

Connect a safety thermostat to the CS contact on the pump connector.

■ **CIRC.CURVE ..**

Heating curve circuit B or C

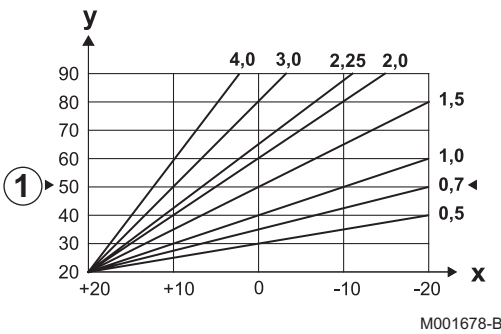

- x** Outside temperature (°C)
- y** Water flow temperature (°C)
- ① Maximum temperature of the circuit B - C

■ **ANTICIP.B, ANTICIP.C**

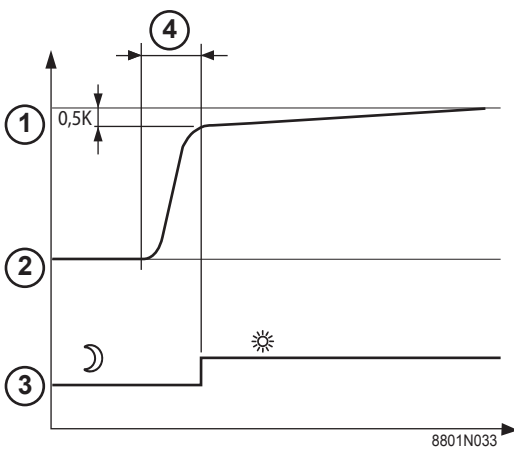

- ① Room temperature setpoint - Comfort
- ② Room temperature setpoint - Reduced
- ③ Time schedule
- ④ Anticipation time = Accelerated reheating phase

The anticipation function calculates the heating restart time to reach the desired room temperature less 0.5 K at the time programmed for switching to comfort mode.

The start time of the timed programmed corresponds to the end of the accelerated reheating phase.

The function is activated by setting a different **OFF** value.

The value set corresponds to the time considered necessary to bring the installation to the required temperature (at outside temperature 0°C), starting from a residual room temperature corresponding to the reduced temperature setpoint.

Anticipation is optimized if a room sensor is connected.

The regulator will automatically fine set the anticipation time.



This function is dependent on the surplus power available in the installation.

■ **SCREED DRYING**

Used to force a constant flow temperature or a train to accelerate screed drying on underfloor heating.

The setting for these temperatures must follow the screed-layer's recommendations.

The activation of this parameter (setting other than **OFF**) forces the permanent display of **SCREED DRYING** and deactivates all other functions on the control unit.

When floor drying is active on a circuit, all other circuits (e.g. DHW) are shut down. The use of this function is only possible on circuits B and C.

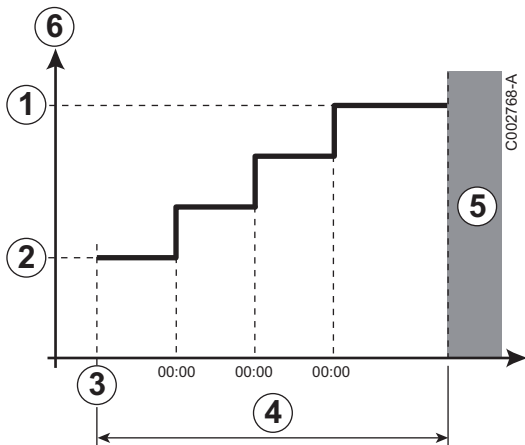

- ① **STOP DRYING TEMP**
- ② **START DRYING TEMP**
- ③ Today
- ④ **NB DAYS DRYING**
- ⑤ Normal regulation (End of drying)
- ⑥ Heating temperature setting (°C)

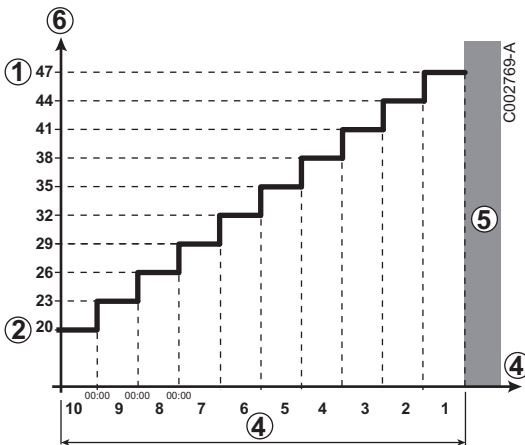

- For example**
- ① **STOP DRYING TEMP: 47 °C**
 - ② **START DRYING TEMP: 20 °C**
 - ④ **NB DAYS DRYING**
 - ⑤ Normal regulation (End of drying)
 - ⑥ Heating temperature setting (°C)



Every day at midnight (00:00): the set point (**START DRYING TEMP**) is recalculated and the remaining number of days (**NB DAYS DRYING**) is decremented.

■ ROOM S.INFL

Used to adjust the influence of the room sensor on the water temperature for the circuit concerned.

Adjustment	Description
0	No influence (remote control fitted in a location with no influence)
1	Slight influence
3	Average influence (recommended)
10	Room thermostat type operation

■ NIGHT



This parameter is displayed if at least one circuit does not include a room sensor.

For circuits without a room sensor:

- ▶ **NIGHT :DEC. (Reduced):** The reduced temperature is maintained during reduced periods. The circuit pump operates constantly.

- ▶ **NIGHT :STOP (Stop):** Heating is shut down during reduced periods. When installation antifreeze is active, the reduced temperature is maintained during reduced periods.

For circuits with a room sensor:

- ▶ When the room temperature is lower than the room sensor set point: The reduced temperature is maintained during reduced periods. The circuit pump operates constantly.
- ▶ When the room temperature is higher than the room sensor set point: Heating is shut down during reduced periods. When installation antifreeze is active, the reduced temperature is maintained during reduced periods.

■ **Function 0-10 V**

This function controls the boiler using an external system that includes a 0-10 V output connected to the 0-10 V input. This command imposes to the boiler a temperature or power setpoint. Be sure that parameter **BOILER MAX** is set higher than **CONS.MAX 0-10V** if the control is done by temperature.

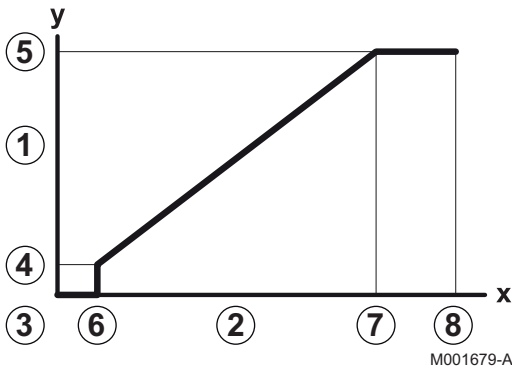

- 1 Flow temperature (°C) or power (%) setpoint
- 2 Voltage at input (V) - DC
- 3 0 V
- 4 **CONS.MIN 0-10V**
- 5 **CONS.MAX 0-10V**
- 6 **VMIN/OFF 0-10V**
- 7 **VMAX 0-10V**
- 8 10 V
- x Voltage at input
- y Boiler temperature or sliding output

If the input voltage is less than **VMIN/OFF 0-10V**, the boiler is off. The boiler temperature setting corresponds strictly to the 0-10 V input. The secondary boiler circuits continue to operate but have no impact on the water temperature in the boiler. If using the 0-10 V input and a secondary boiler circuit, the external regulator providing this 0-10 V power supply must always request a temperature at least equal to the needs of the secondary circuit.

■ **MAX FLOW**

In order for the regulator to calculate the quantity of heat produced by the installation (parameter kWh), input parameter **MAX FLOW**. The parameter **MAX FLOW** is equal to the flow in litres per minute in the solar circuit.

Establish the **MAX FLOW** value with the help of the table below, according to the configuration of the installation and the number or surface area of collectors.

When the flow is input incorrectly, the display kWh will also be incorrect.



The quantity of heat (kWh value) can only be used for checks carried out for personal reasons.

Flat solar collectors				
Solar panel installation	Area (m ²)	Number of panels	Flow rate (l/h)	Flow rate (l/min)
	3...5	1 or 2	400	6,7
	6...8	3 or 4	300	5,0
	8...10	4 or 5	250	4,1
	8...10	2x2	750	12,5
	12...15	2x3	670	11,2
	16...20	2x4	450	7,5
	12...15	3x2	850	14,2
	18...23	3x3	800	13,4
	24...30	3x4	650	10,9
	16...20	4x2	1200	20,0
	24...30	4x3	850	14,2

5.6.5. Configuring the network

1. Access the installer level: Press key for around 5 seconds.
2. Select the menu **#NETWORK**.



- ▶ Turn the rotary button to scroll through the menus or modify a value.
- ▶ Press the rotary button to access the selected menu or confirm a value modification.

For a detailed explanation of menu browsing, refer to the chapter: "Browsing in the menus", page 40

3. Set the following parameters:

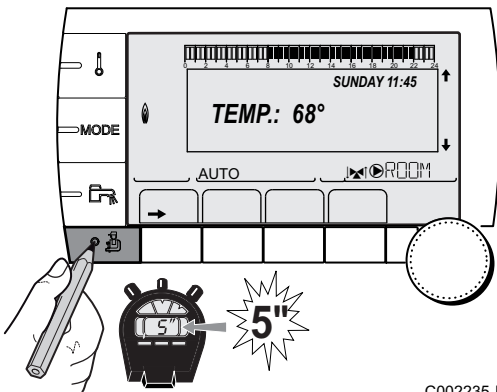

C002235-F-04

Installer level - #NETWORK Menu ⁽¹⁾				
Parameter	Adjustment range	Description	Factory setting	Customer setting
VM NUMBER⁽²⁾	20 to 39	Set the module's network address	20	
CASCADE⁽²⁾	ON / NO	ON: System in cascade	NO	
VM NETWORK⁽²⁾		Specific menu: Enlist VMs in cascade mode See chapter: "Connecting VM iSense Pro in cascade", page 59		
MASTER CONTROLER⁽³⁾	ON / NO	Configure this control system as master on the bus	ON	
SYSTEM NETWORK⁽⁴⁾		Specific menu: Enlist VMs in cascade mode See chapter: "Connecting VM iSense Pro in cascade", page 59		

(1) The menu is displayed only if the **INSTALLATION** parameter is set to **EXTENDED**

(2) According to the configuration

(3) The parameter is only displayed if **CASCADE** is set to **ON**

(4) The parameter is only displayed if **MASTER CONTROLER** is set to **ON**

(5) The parameter is only displayed if **FUNCT** is set to **PARALLEL**

(6) The parameter is only displayed if **MASTER CONTROLER** is set to **OFF**

Installer level - #NETWORK Menu ⁽¹⁾				
Parameter	Adjustment range	Description	Factory setting	Customer setting
FUNCT ⁽⁴⁾	TRADITIONAL	Operation in cascade: Successive triggering of the various boilers in the cascade according to requirements	TRADITIONAL	
	PARALLEL	Functioning in parallel cascade: If the outside temperature is lower than the value PARALLEL.CASC , all of the boilers are started up at the same time		
PARALLEL.CASC ⁽⁵⁾	-10 to 20 °C	Outside temperature triggering all stages in parallel mode	10 °C	
TIMER GENE P.CASC ⁽³⁾	0 to 30 min	Minimum duration of post-operation of the generator pump	0 mn	
INTER STAGE TIMER ⁽³⁾	1 to 60 min	Time delay for starting up or shutting down generators.	4 mn	
SLAVE NUMBER ⁽⁶⁾	2 to 10	Set the network address of the secondary generator	2	

(1) The menu is displayed only if the **INSTALLATION** parameter is set to **EXTENDED**
 (2) According to the configuration
 (3) The parameter is only displayed if **CASCADE** is set to **ON**
 (4) The parameter is only displayed if **MASTER CONTROLER** is set to **ON**
 (5) The parameter is only displayed if **FUNCT** is set to **PARALLEL**
 (6) The parameter is only displayed if **MASTER CONTROLER** is set to **OFF**

User level - #SETTING Menu				
Parameter	Adjustment range	Description	Factory setting	Customer setting
PERMUT ⁽¹⁾	AUTO / 1 ... 10	This parameter is used to set the master boiler. ▶ AUTO : The master boiler switches automatically every 7 days ▶ 1 ... 10: The master boiler is always the one defined by this value	AUTO	

(1) The parameter is only displayed if **CASCADE** is on **ON** and **MASTER CONTROLER** on **ON**

■ Connecting appliances in cascade

It is possible, in a cascade configuration, to enlist generators and/or VM iSense Pro as slaves. Proceed as follows:

1. Set parameter **CASCADE** to **ON**.
2. Select **SYSTEM NETWORK** and press the rotary button to go to the specific menu.

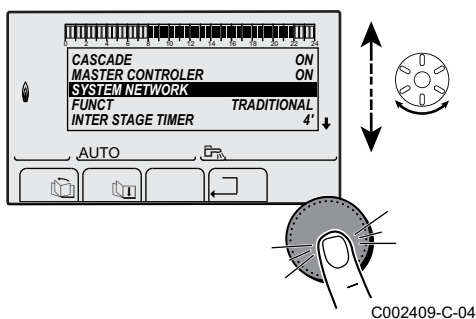

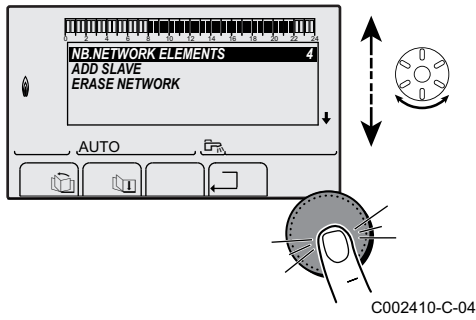

3. To add a slave appliance to the network, select **ADD SLAVE**.

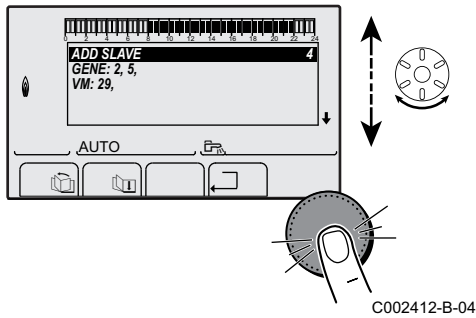

4. The screen displayed allows you to choose numbers for the slave boilers to be added to the network. Numbers 2 to 10 are dedicated to the generators and numbers 20 to 39 to the VM iSense Pro. Turn the rotary button to scroll through the numbers and press to confirm the number chosen. Press \square to go back to the previous list.

5. To remove a slave appliance from the network, select **ERASE NETWORK**.

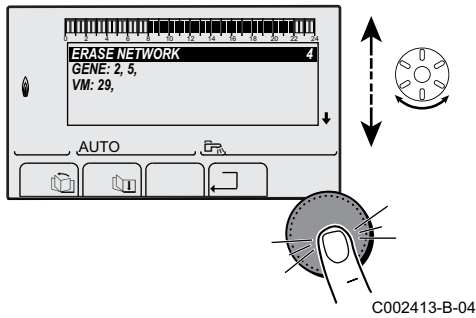

6. The screen displayed allows you to choose the numbers of the slave boilers to be removed from the network. Turn the rotary button to scroll through the numbers and press to remove the number chosen. Press \square to go back to the previous list.

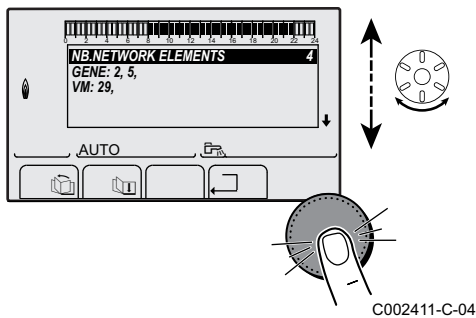

7. Select **NB.NETWORK ELEMENTS**. This screen summarises the elements in the network recognized by the system. Press \square to go back to the previous list.

■ Connecting VM iSense Pro in cascade

It is possible to assign VMs only as slaves. Proceed as follows:

1. Select **VM NETWORK** and press the rotary button to go to the specific menu.
2. The screen displayed is used to select the numbers of the slave VMs to be added to the network. Numbers 20 to 39 are dedicated to the VMs. Turn the rotary button to scroll through the numbers and press to confirm the number chosen. Press \square to go back to the previous list.
3. To remove a slave VM from the network, select **ERASE VM**.

4. The screen displayed is used to select the numbers of the slave VMs to be removed from the network. Turn the rotary button to scroll through the numbers and press to remove the number chosen. Press \square to go back to the previous list.
5. Select **NB.NETWORK ELEMENTS**. This screen summarises the elements in the network recognized by the system. Press \square to go back to the previous list.

5.6.6. Return to the factory settings

To reset the appliance, proceed as follows:

1. Press key \downarrow , \rightarrow and \square simultaneously for 4 seconds. The menu **#RESET** is displayed.
2. Set the following parameters:

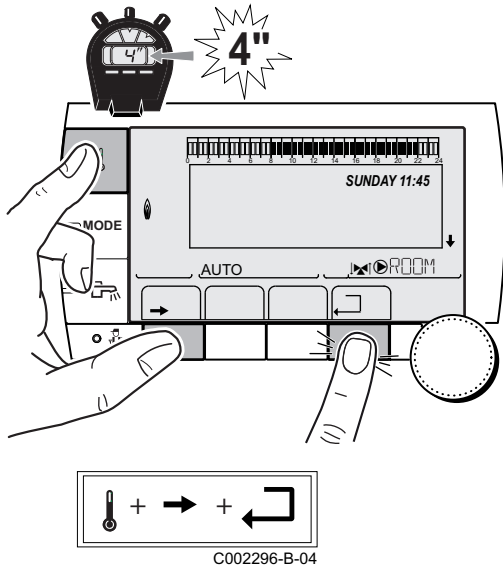

#RESET Menu			
Choice of generator	Parameter		Description
GENERATOR	RESET	TOTAL	Performs a TOTAL RESET of all parameters
		EXCEPT PROG.	Performs a parameter RESET but retains the timer programmes
		PROG.	Performs a RESET on the timer programmes but retains the parameters
		SENSOR SCU	Performs a RESET of the generator sensors connected
		ROOM SENSOR	Performs a RESET of the room sensors connected

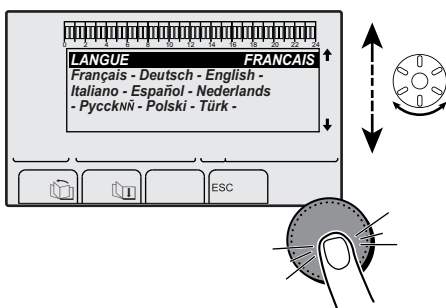

After reset (**TOTAL RESET** and **RESET EXCEPT PROG.**), the control system goes back to the display of the language choice after a few seconds.

1. Select the desired language by turning the rotary button.
2. To confirm, press the rotary button.

6 Switching off the appliance

6.1 Installation shutdown



CAUTION

Do not switch off the mains supply to the appliance. If the central heating system is not used for a long period, we recommend activating the **HOLIDAYS** mode (to ensure the anti-grip of the heating pump).

6.2 Antifreeze protection



CAUTION

- ▶ The antifreeze protection does not function if the appliance is switched off.
- ▶ To protect the installation, set the appliance to **HOLIDAYS** mode.

The **HOLIDAYS** mode protects:

- ▶ The installation if the outside temperature is lower than 3°C (factory setting).
- ▶ The room temperature if a remote control is connected and the room temperature is lower than 6 °C (factory setting).
- ▶ The domestic hot water tank if the tank temperature is lower than 4 °C (the water is reheated to 10 °C).

To configure the holidays mode:  Refer to the user instructions.

7 Troubleshooting

7.1 Installer’s contact details

To display the installer’s telephone number when an error is displayed, proceed as follows:

1. Access the "After Sales" level: Hold key  down until **#PARAMETERS** is displayed.
2. Select the menu **#SUPPORT**.



- ▶ Turn the rotary button to scroll through the menus or modify a value.
- ▶ Press the rotary button to access the selected menu or confirm a value modification.

 For a detailed explanation of menu browsing, refer to the chapter: "Browsing in the menus", page 40

3. Set the following parameters:

After Sales level - #SUPPORT menu	
Parameter	Description
NAME	Input the installer’s name
TEL	Input the installer’s telephone number

When an error is displayed, press ? to display the installer’s telephone number.

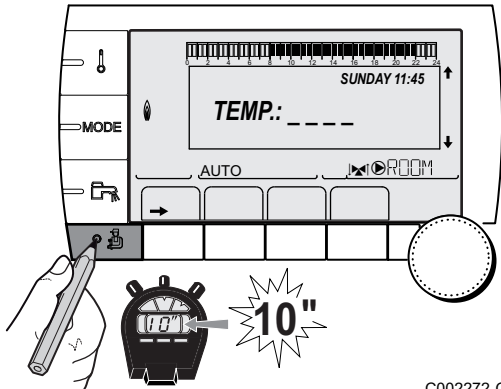

C002272-C-04

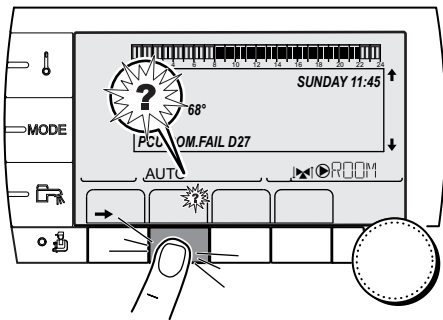

C002302-D-04

7.2 Messages (type code Mxx)

The module may display the following messages:

Code no.	Messages	Description	Checking / solution
	FL.DRY.B XX DAYS	Floor drying is active XX DAYS = Number of days' floor drying remaining.	Floor drying is underway. Heating on the circuits not concerned is shut down. ▶ Wait for the number of days shown to change to 0 ▶ Set the parameter SCREED DRYING to OFF
	FL.DRY.C XX DAYS		
	FL.DRY.B+C XX DAYS		

Code no.	Messages	Description	Checking / solution
	STOP N XX	The shutdown is active XX = Number of the active shutdown	A shutdown is underway. The circuits selected for this stop are in Antifreeze mode during the period chosen. <ul style="list-style-type: none"> ▶ Wait until the end date has been passed ▶ Set the parameter STOP N XX to OFF
M23	CHANGE OUTSI.S	The outside temperature sensor is defective.	Change the outside radio temperature sensor.
M30	BL.COM MODBUS	No communication with the master regulation through the MODBUS network.	Check the wiring between the module and the master appliance.
M31	BL.SYSTEM NETWORK	Incorrect configuration of the MODBUS network.	<ul style="list-style-type: none"> ▶ Check that the address of the appliance is correctly configured in the #NETWORK menu. ▶ Check that the cascade configuration is set correctly on the master module.

7.3 Message history

The menu **#MESSAGE HISTORIC** is used to consult the last 10 messages displayed by the control panel.

1. Access the "After Sales" level: Hold down the  key until **#PARAMETERS** is displayed.
2. Select the menu **#MESSAGE HISTORIC**.

-  Turn the rotary button to scroll through the menus or modify a value.
- ▶ Press the rotary button to access the selected menu or confirm a value modification.

 For a detailed explanation of menu browsing, refer to the chapter: "Browsing in the menus", page 40

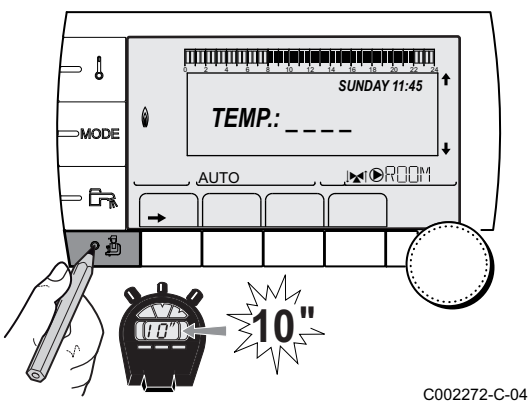

3. The list of the last 10 messages is displayed.

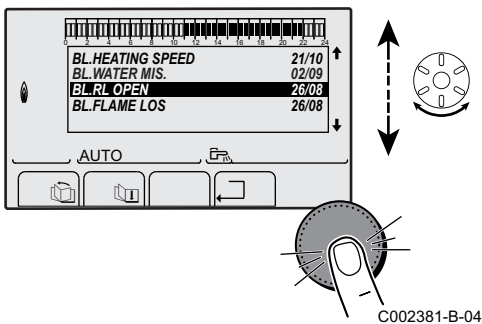

4. Select a message to consult the information pertaining to it.

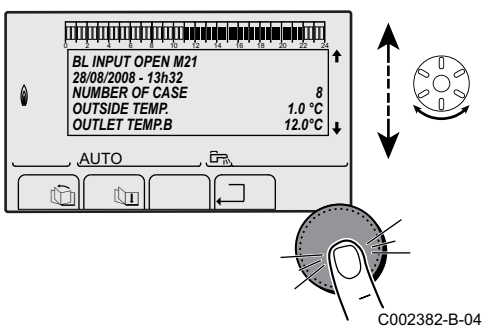

7.4 Faults



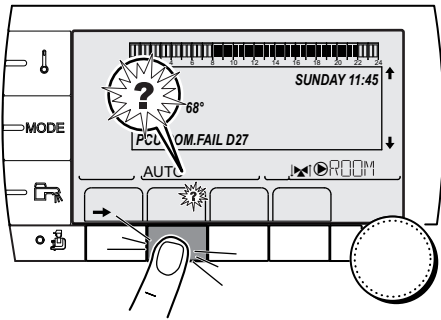

If a malfunction occurs, the module flashes and displays an error message and a corresponding code.



1. Make a note of the code displayed.
The code is important for the correct and rapid diagnosis of the type of failure and for any technical assistance that may be needed.
2. Press the ? key. Follow the instructions displayed to solve the problem.
3. Consult the meaning of the codes in the table below:



C002302-D-04

Code	Faults	Description	Checking / solution
D03 D04	OUTL S.B FAIL. OUTL S.C FAIL.	Circuit B flow sensor fault Circuit C flow sensor fault Remarks: The circuit pump is running. The 3-way valve motor on the circuit is no longer powered and can be adjusted manually.	Bad connection <ul style="list-style-type: none"> ▶ Check whether the sensor is connected: See chapter: "Deletion of sensors from the memory in the PCB", page 66 ▶ Check the link and the connectors ▶ Check that the sensor has been correctly fitted Sensor fault <ul style="list-style-type: none"> ▶ Check the Ohmic value of the sensor ▶ Replace the sensor if necessary
D05	OUTSI.S.FAIL.	Outside temperature sensor fault Remarks: The set point of the appliance is equal to the maximum. The valve setting is no longer ensured but monitoring the maximum temperature of the circuit after the valve is ensured. Valves may be manually operated. Reheating the domestic hot water remains ensured.	Bad connection <ul style="list-style-type: none"> ▶ Check whether the sensor is connected ▶ Check the link and the connectors ▶ Check that the sensor has been correctly fitted Sensor fault <ul style="list-style-type: none"> ▶ Check the Ohmic value of the sensor ▶ Replace the sensor if necessary
D07	SYST.SENS.FAIL.	System sensor fault	Bad connection <ul style="list-style-type: none"> ▶ Check whether the sensor is connected: See chapter: "Deletion of sensors from the memory in the PCB", page 66 ▶ Check the link and the connectors ▶ Check that the sensor has been correctly fitted Sensor fault <ul style="list-style-type: none"> ▶ Check the Ohmic value of the sensor ▶ Replace the sensor if necessary

Code	Faults	Description	Checking / solution
D09	DHW S.FAILURE	Domestic hot water sensor fault Remarks: Domestic hot water heating is no longer controlled. The load pump operates. The load temperature of the dhw tank is the same as the boiler.	Bad connection <ul style="list-style-type: none"> ▶ Check whether the sensor is connected:  See chapter: "Deletion of sensors from the memory in the PCB", page 66 ▶ Check the link and the connectors ▶ Check that the sensor has been correctly fitted Sensor fault <ul style="list-style-type: none"> ▶ Check the Ohmic value of the sensor ▶ Replace the sensor if necessary
D12 D13	ROOM S.B FAIL. ROOM S.C FAIL.	B room temperature sensor fault C room temperature sensor fault Note: The circuit concerned operates without any influence from the room sensor.	Bad connection <ul style="list-style-type: none"> ▶ Check whether the sensor is connected:  See chapter: "Deletion of sensors from the memory in the PCB", page 66 ▶ Check the link and the connectors ▶ Check that the sensor has been correctly fitted Sensor fault <ul style="list-style-type: none"> ▶ Check the Ohmic value of the sensor ▶ Replace the sensor if necessary
D14	MC COM.FAIL	Break in communication between the iSense Pro module and the boiler radio module	Bad connection <ul style="list-style-type: none"> ▶ Check the link and the connectors Boiler module failure <ul style="list-style-type: none"> ▶ Change the boiler module
D15	ST.TANK S.FAIL	Storage tank sensor fault Note: The hot water storage tank reheating operation is no longer assured.	Bad connection <ul style="list-style-type: none"> ▶ Check whether the sensor is connected:  See chapter: "Deletion of sensors from the memory in the PCB", page 66 ▶ Check the link and the connectors ▶ Check that the sensor has been correctly fitted Sensor fault <ul style="list-style-type: none"> ▶ Check the Ohmic value of the sensor ▶ Replace the sensor if necessary
D16 D16	SWIM.B S.FAIL SWIM.C S.FAIL	Swimming pool sensor fault circuit B Swimming pool sensor fault circuit C Note: Pool reheating is independent of its temperature.	Bad connection <ul style="list-style-type: none"> ▶ Check whether the sensor is connected:  See chapter: "Deletion of sensors from the memory in the PCB", page 66 ▶ Check the link and the connectors ▶ Check that the sensor has been correctly fitted Sensor fault <ul style="list-style-type: none"> ▶ Check the Ohmic value of the sensor ▶ Replace the sensor if necessary
D17	DHW 2 S.FAIL	Sensor fault tank 2	Bad connection <ul style="list-style-type: none"> ▶ Check whether the sensor is connected:  See chapter: "Deletion of sensors from the memory in the PCB", page 66 ▶ Check the link and the connectors ▶ Check that the sensor has been correctly fitted Sensor fault <ul style="list-style-type: none"> ▶ Check the Ohmic value of the sensor ▶ Replace the sensor if necessary

Code	Faults	Description	Checking / solution
D18	ST.TANK S.FAIL	Solar tank sensor fault	<p>Bad connection</p> <ul style="list-style-type: none"> ▶ Check whether the sensor is connected:  See chapter: "Deletion of sensors from the memory in the PCB", page 66 ▶ Check the link and the connectors ▶ Check that the sensor has been correctly fitted <p>Sensor fault</p> <ul style="list-style-type: none"> ▶ Check the Ohmic value of the sensor ▶ Replace the sensor if necessary
D19	SOL.COL.S.FAIL	Header sensor fault	<p>Bad connection</p> <ul style="list-style-type: none"> ▶ Check whether the sensor is connected:  See chapter: "Deletion of sensors from the memory in the PCB", page 66 ▶ Check the link and the connectors ▶ Check that the sensor has been correctly fitted <p>Sensor fault</p> <ul style="list-style-type: none"> ▶ Check the Ohmic value of the sensor ▶ Replace the sensor if necessary
D20	SOL.COM.FAIL	<ul style="list-style-type: none"> ▶ Switch the boiler off and switch back on ▶ Check whether the solar module is switched on. If necessary, replace the fuse  Refer to the installation, commissioning and service manual for the DHW tank ▶ Check the connection between the SCU-C and the solar module 	
D50	OTH.COM.FAIL	Break in communication between the iSense Pro module and the boiler control panel.	<ul style="list-style-type: none"> ▶ Check the wiring between the iSense Pro module and the control panel ▶ Check that the CONFIGURATION parameter in the #SYSTEM menu is set to OTH+3WV
D51	DEF XX:SEE BOIL.	An error is displayed on the boiler control panel.	<ul style="list-style-type: none"> ▶ Refer to the boiler's installation and service manual.

7.4.1. Deletion of sensors from the memory in the PCB

The configuration of the sensors is memorised by the PCB. If a sensor fault appears whilst the corresponding sensor is not connected or has been voluntarily removed, please delete the sensor from the PCB memory.

- ▶ Press key **?** repeatedly until **Do you want to delete this sensor?** is displayed.
- ▶ Select **YES** by turning the rotary button and press to confirm.



A defective outside temperature sensor cannot be deleted from the SCU PCB.

7.5 Failure history

The menu **#DEFAULT HISTORIC** is used to consult the last 10 faults displayed by the control panel.

1. Access the "After Sales" level: Hold down the  key until **#PARAMETERS** is displayed.
2. Select the menu **#DEFAULT HISTORIC** .



- ▶ Turn the rotary button to scroll through the menus or modify a value.
- ▶ Press the rotary button to access the selected menu or confirm a value modification.

 For a detailed explanation of menu browsing, refer to the chapter: "Browsing in the menus", page 40

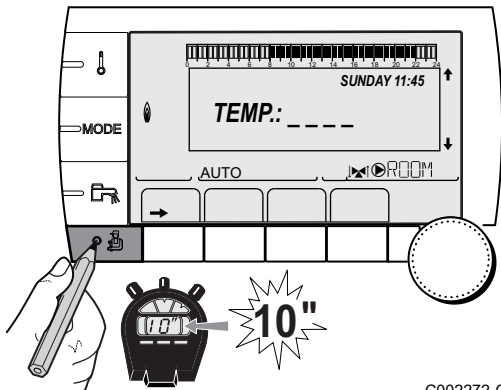

C002272-C-04

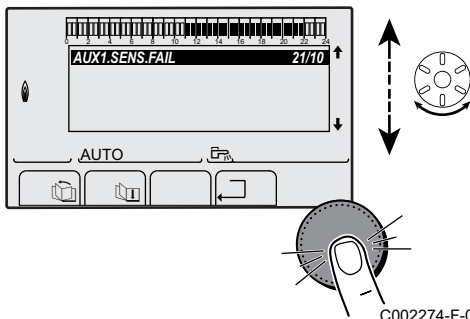

C002274-F-04

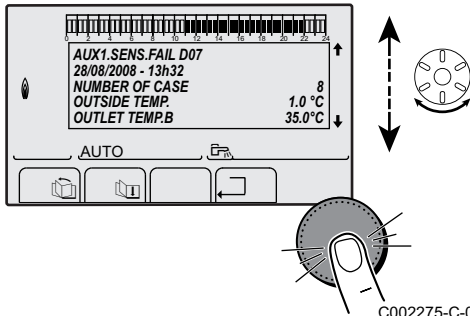

C002275-C-04

3. The list of the last 10 faults is displayed.

4. Select a fault to consult the information pertaining to it.

7.6 Parameter and input/output check (mode tests)

Use the following menus to target the cause of a malfunction.

1. Access the "After Sales" level: Hold down the  key until **#PARAMETERS** is displayed.
2. Check the following parameters:



- ▶ Turn the rotary button to scroll through the menus or modify a value.
- ▶ Press the rotary button to access the selected menu or confirm a value modification.

 For a detailed explanation of menu browsing, refer to the chapter: "Browsing in the menus", page 40

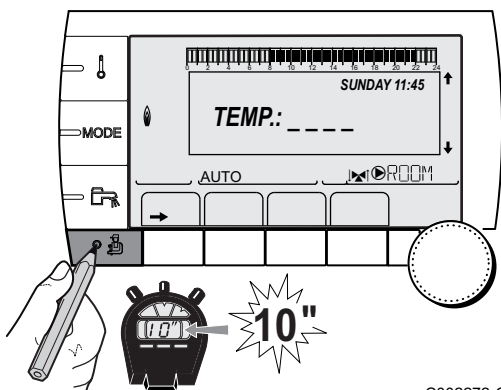

C002272-C-04

After Sales level - #PARAMETERS menu	
Parameter	Description
PERMUT	Master boiler active
STAGE	Number of boilers requesting heating
NB.CASC. ⁽¹⁾	Number of boilers recognised in the cascade
NB. VM: ⁽¹⁾	Number of VM iSense Pro control systems recognised in the cascade
OUTPUT SOL P.	Solar pump command
MEAN OUTSIDE T	Average outside temperature
CALC.T.BOILER ⁽¹⁾	Temperature calculated by the boiler
BOILER.T. ⁽²⁾	Measurement of the boiler flow sensor
CALCULATED T. B ⁽³⁾	Calculated temperature for circuit B
CALCULATED T. C ⁽³⁾	Calculated temperature for circuit C
DHW SETP.CORRECT ⁽³⁾	DHW set point used by the boiler bearing solar back-up in mind
OUTLET TEMP.B ^{(2) (3)}	Temperature of the flow water in circuit B
OUTLET TEMP.C ^{(2) (3)}	Temperature of the flow water in circuit C
OUTSIDE TEMP. ⁽²⁾	Outside temperature
ROOMTEMP.B ^{(2) (3)}	Room temperature of circuit B
ROOMTEMP.C ^{(2) (3)}	Room temperature of circuit C
DHW TEMP. ⁽²⁾⁽³⁾	Water temperature in the DHW tank
IN 0-10V ⁽²⁾⁽³⁾	Voltage at input 0-10 V
STOR.TANK.TEMP ^{(2) (3)}	Water temperature in the storage tank
TEMP.SYSTEM ⁽²⁾⁽³⁾	Temperature of the system flow water if multi-generator
T.DHW BOTTOM ⁽²⁾⁽³⁾	Water temperature in the bottom of the DHW tank
TEMP.TANK AUX ⁽²⁾⁽³⁾	Water temperature in the second DHW tank connected to the AUX circuit
KNOB B ⁽³⁾	Position of temperature setting button on room sensor B
KNOB C ⁽³⁾	Position of temperature setting button on room sensor C
OFFSET ADAP B ⁽³⁾	Parallel trigger calculated for circuit B
OFFSET ADAP C ⁽³⁾	Parallel trigger calculated for circuit C
<p>(1) According to the configuration</p> <p>(2) The parameter can be displayed by pressing key μ.</p> <p>(3) The parameter is only displayed for the options, circuits or sensors actually connected</p>	

After Sales level - #TEST OUTPUTS menu		
Parameter	Adjustment range	Description
P.CIRC.B ⁽¹⁾	ON / NO	Stop/start pump circuit B
P.CIRC.C ⁽³⁾	ON / NO	Stop/start pump circuit C
HW.PUMP ⁽³⁾	ON / NO	Stop/start domestic hot water pump
AUX.CIRC. ⁽³⁾	ON / NO	On/Off auxiliary outlet
SOLAR P. ⁽³⁾	ON / NO	Solar pump On/Off
3WV B ⁽³⁾	REST	No command
	OPEN:	Opening 3-way valve circuit B
	CLOSE:	Closure 3-way valve circuit B
3WV C ⁽³⁾	REST	No command
	OPEN:	Opening 3-way valve circuit C
	CLOSE:	Closure 3-way valve circuit C
<p>(1) The parameter is only displayed for the options, circuits or sensors actually connected</p>		

After Sales level - #TEST INPUTS menu		
Parameter	Status	Description
PHONE REM. ⁽¹⁾	0 / 1	Status of the telephone inlet
I.SYST ⁽²⁾	0 / 1	Status of the telephone inlet
R.CTRL B ⁽³⁾	ON	Presence of a remote control B
	NO	No remote control B
R.CTRL C ⁽³⁾	ON	Presence of a remote control C
	NO	No remote control C

(1) The parameter is only displayed if **IN 0-10V** is set to **OFF**
(2) According to the setting of the **I.SYST** parameter
(3) The parameter is only displayed for the options, circuits or sensors actually connected

After Sales level - #INFORMATION menu ⁽¹⁾		
Parameter	Adjustment range	Description
S/N SCU		Serial no. of the iSense Pro DIN control panel
CTRL		Control version
MC.VERSION ⁽²⁾		Version of the boiler radio module programme
CALIBRA.CLOCK		Clock calibration

(1) The menu is displayed only if the **INSTALLATION** parameter is set to **EXTENDED**
(2) The parameter is only displayed for the options, circuits or sensors actually connected

After Sales level - #CONFIGURATION menu		
Parameter	Adjustment range	Description
MODE:	MONO/ ALL.CIRC	To chose if the exemption made for one remote control applies to a single circuit (MONO) or if it must be transmitted to a group of circuits (ALL CIRC)

8 Spare parts

8.1 General

When it is observed subsequent to inspection or maintenance work that a component in the appliance needs to be replaced, use only original spare parts or recommended spare parts and equipment.

Send the component to be replaced to your supplier's Returned Goods Department if the component in question is under warranty (see general terms and conditions of sale and delivery).



Always ensure that your return package is accompanied by the completed return form, see attached example. In this way, your supplier can fulfil his warranty obligations more easily and more effectively.

Customer						
Reference					Date	
Name						
Address						
Town/Postcode						
Telephone						
Contact person						
Order number						
Code no.	Description	Serial number⁽¹⁾	Type	Installation date	Reason for the exchange	Reference
(1) This information can be found on the rating plate.						

8.2 Spare parts

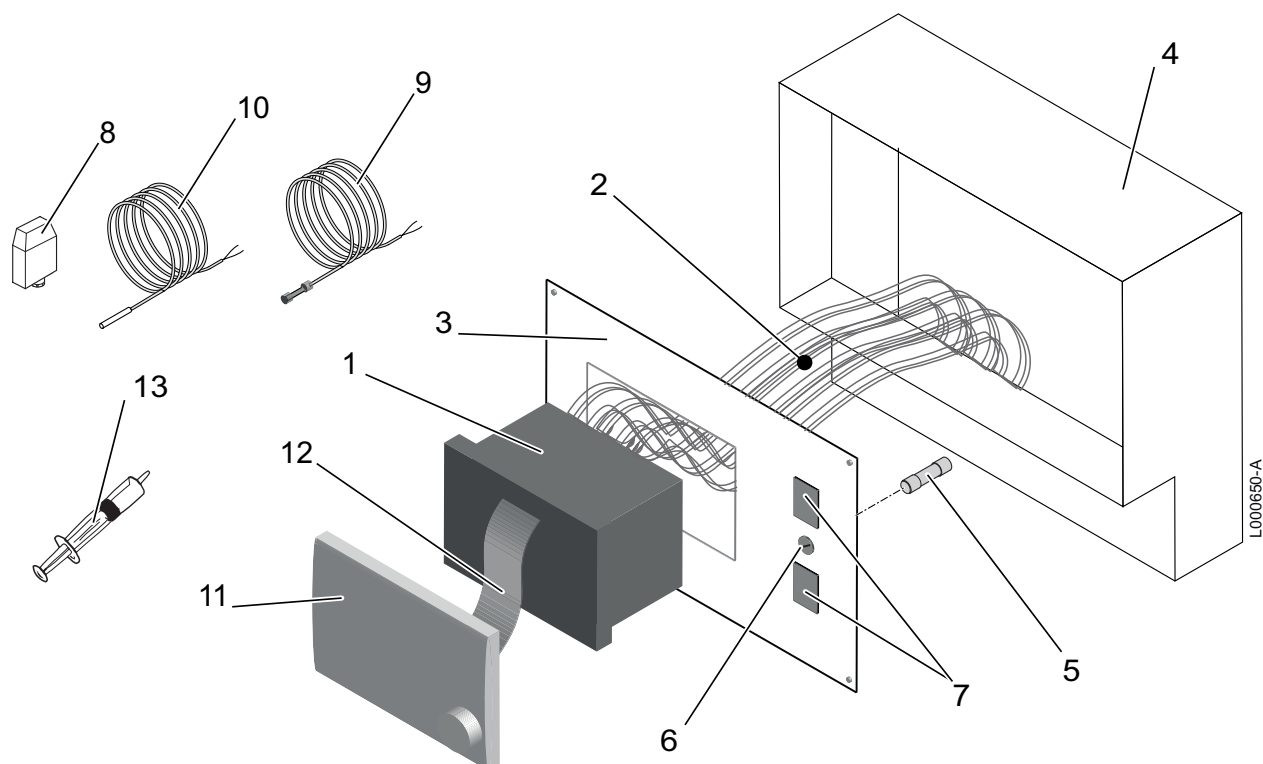

Markers	Code no.	Description
1	300029233	VM iSense Pro regulator
2	300029234	Electrical harness
3	300029237	Front panel
4	300029238	Box
5	300029239	Fuse
6	300029240	Fuse holder
7	300029241	Switch
8	95362450	Outside sensor
9	95362449	Outlet sensor
10	95362448	KVT sensor 60 l. 5 m
11	S101249	Display
12	200016858	Flat cable
13	97385252	Syringe

Remeha Commercial UK
Innovations House
3 Oaklands Business Centre
Oaklands Park
RG41 2FD WOKINGHAM,

Tel: +44 118 9783434
Fax: +44 118 9786977
Internet: www.remeha.co.uk
E-mail: boilers@remeha.co.uk.



© Copyright

All technical and technological information contained in these technical instructions, as well as any drawings and technical descriptions supplied, remain our property and shall not be multiplied without our prior consent in writing.

18/12/2014



300027279-001-03

 **remeha**

The Remeha logo symbol is a stylized 'R' inside a square frame. The word 'remeha' is written in a bold, lowercase, sans-serif font to the right of the symbol.